

B25E

HOOKLIFT TRUCK

6x6

Articulated Dump Trucks

Stage II Certified



- Gross Power: 205 kW (275 hp)
- Operating Weight: 43 660 kg (96 252 lbs)

BELL

B25E Hooklift Articulated Dump Truck



ENGINE

Manufacturer
Mercedes Benz

Model
OM906LA

Configuration
Inline 6, turbocharged and intercooled

Gross Power
205 kW (275 hp) @ 2 200 rpm

Net Power
198 kW (265 hp) @ 2 200 rpm

Gross Torque
1 100 Nm (811 lbft)
@ 1 200 - 1 600 rpm

Displacement
6,37 litres (389 cu.in)

Auxiliary Brake
Exhaust valve brake
Engine valve brake

Fuel Tank Capacity
379 litres (100 US gal)

Certification
OM906LA meets EU Stage II/EPA Tier 2 emissions regulations

TRANSMISSION

Manufacturer
Allison

Model
3500PR ORS

Configuration
Fully automatic planetary transmission with integral retarder.

Layout
Engine mounted

Gear Layout
Constant meshing planetary gears, clutch operated

Gears
6 Forward, 1 Reverse

Clutch Type
Hydraulically operated multi-disc

Control Type
Electronic

Torque Control
Hydrodynamic with lock-up in all gears

TRANSFER CASE

Manufacturer
Kessler

Series
W1400

Layout
Remote mounted

Gear Layout
Three in-line helical gears

Output Differential
Interaxle 33/67 proportional differential. Automatic inter-axle differential lock.

AXLES

Manufacturer
Bell

Model
15T

Differential
High input limited slip differential with spiral bevel gears

Final Drive
Outboard heavy duty planetary on all axles

BRAKING SYSTEM

Service Brake
Dual circuit, full hydraulic actuation dry disc brakes with 8 calipers (4F, 2M, 2R).

Maximum brake force:
184 kN (41 400 lbf)

Park & Emergency
Spring applied, air released driveline mounted disc

Maximum brake force:
195 kN (43 900 lbf)

Auxiliary Brake
Automatic engine valve brake. Automatic, adjustable, integral, hydrodynamic transmission retarder.
Output shaft speed dependant.

Total Retardation Power
Continuous: 318 kW (426 hp)
Maximum: 588 kW (788 hp)

WHEELS

Type
Radial Earthmover

Tyre
23.5 R 25

FRONT SUSPENSION

Semi-independent, leading A-frame supported by hydro-pneumatic suspension struts.

REAR SUSPENSION

Pivoting walking beams with laminated rubber suspension blocks.

HYDRAULIC SYSTEM

Full load sensing system serving the prioritized steering, body tipping and brake functions. A ground-driven, load sensing emergency steering pump is integrated into the main system.

Pump Type
Variable displacement load sensing piston

Flow
165 l/min (44 gal/min)

Pressure
28 MPa (4 061 psi)

Filter
5 microns

STEERING SYSTEM

Double acting cylinders, with ground-driven emergency steering pump.

Lock to lock turns
4,1

Steering Angle
45°

HOOK LIFT SYSTEM

Two double-acting, single stage

Tipping Angle
50° standard, or any lower angle programmable

PNEUMATIC SYSTEM

Air drier with heater and integral unloader valve, serving park brake and auxiliary functions.

System Pressure
810 kPa (117 psi)

ELECTRICAL SYSTEM

Voltage
24 V

Battery Type
Two AGM (Absorption Glass Mat) type

Battery Capacity
2 X 75 Ah

Alternator Rating
28V 80A

VEHICLE SPEEDS

1st	7 km/h	4 mph
2nd	15 km/h	9 mph
3rd	23 km/h	14 mph
4th	35 km/h	22 mph
5th	47 km/h	29 mph
6th	50 km/h	31 mph
R	7 km/h	4 mph

CAB

ROPS/FOPS certified 74 dBA internal sound level measured according to ISO 6396.

Load Capacity & Ground Pressure

OPERATING WEIGHTS		GROUND PRESSURE			
LADEN	kg (lb)	LADEN (No sinkage)		LADEN (15% sinkage)	
Front	14 324 (31 579)				
Middle	14 710 (32 430)	23.5 R 25	kPa (Psi)	23.5 R 25	kPa (Psi)
Rear	14 626 (31 583)	Front	302 (44)	Front	258 (44)
Total	43 660 (96 252)	Middle	311 (45)	Middle	266 (51)
		Rear	311 (45)	Rear	266 (51)

Dimensions

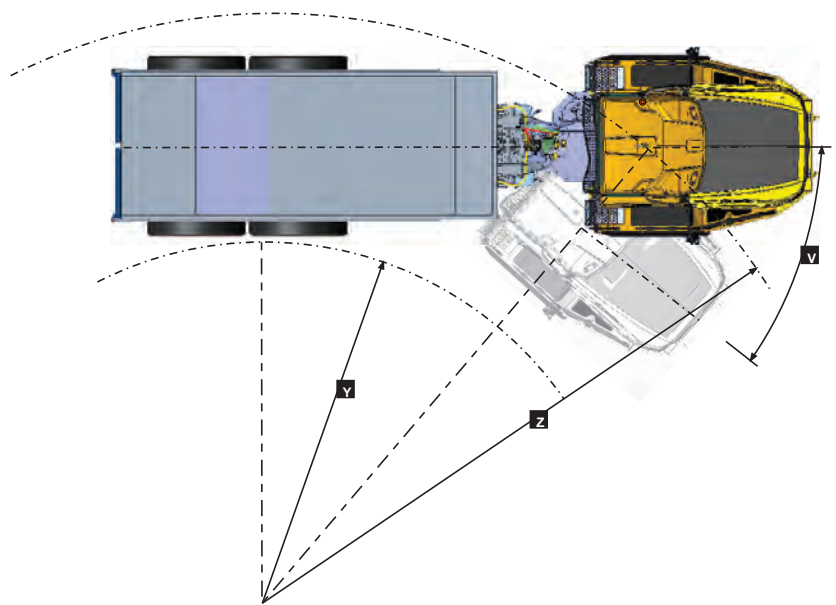
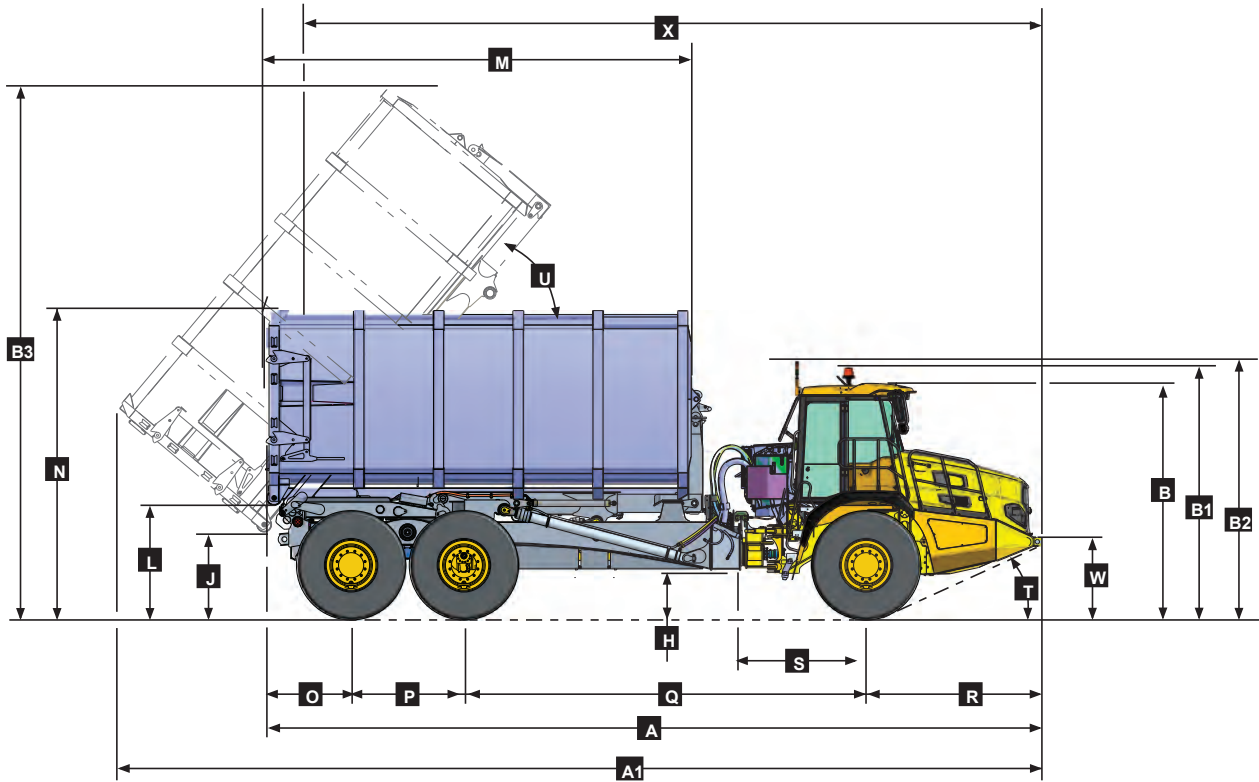

Machine Dimensions

A	Length - Transport Position	11 408 mm (37 ft. 43 in.)	L	Skip Lip Height - Transport Position	1 665 mm (5 ft. 46 in.)
A1	Length - Skip Fully Tipped	13 506 mm (44 ft. 4 in.)	M	Skip Length	6 450 mm (21 ft. 2 in.)
B	Height - Transport Position	3 426 mm (11 ft. 2 in.)	N	Load over Height	4 465 mm (14 ft. 8 in.)
B1	Height - Rotating Beacon	3 661 mm (12 ft.)	O	Rear Axle Centre to Skip Rear	1 320 mm (4 ft. 4 in.)
B2	Height - Load Light	3 747 mm (12 ft. 3 in.)	P	Mid Axle Centre to Rear Axle Centre	1 670 mm (5 ft. 5 in.)
B3	Skip Height - Fully Tipped	7 724 mm (25 ft. 4 in.)	Q	Mid Axle Centre to Front Axle Centre	5 955 mm (19 ft. 6 in.)
C	Width over Mudguards	2 985 mm (9 ft. 9 in.)	R	Front Axle Centre to Machine Front	2 602 mm (8 ft. 6 in.)
D	Width over Tyres - 23.5R25	2 940 mm (9 ft. 7 in.)	S	Front Axle Centre to Artic Centre	1 362 mm (4 ft. 5 in.)
D1	Width over Tyres - 750/65 R25	2 998 mm (9 ft. 84 in.)	T	Approach Angle	25 °
E	Tyre Track Width - 23.5R25	2 356 mm (7 ft. 8 in.)	U	Maximum Skip Tip Angle	50 °
E1	Tyre Track Width - 750/65 R25	2 260 mm (7 ft. 41 in.)	V	Maximum Articulation Angle	45 °
F	Width over Skip	2 500 mm (8 ft. 2 in.)	W	Front Tie Down Height	1 191 mm (3 ft. 91 in.)
G	Width over Mirrors - Operating Position	3 260 mm (10 ft. 8 in.)	X	Machine Lifting Centres	11 156 mm (36 ft. 7 in.)
H	Ground Clearance - Artic	537 mm (21.14 in.)	Y	Inner Turning Circle Radius - 23.5R25	4 110 mm (13 ft. 5 in.)
I	Ground Clearance - Front Axle	488 mm (19.21 in.)	Y1	Inner Turning Circle Radius - 750/65 R25	4 081 mm (13 ft. 39 in.)
J	Ground Clearance - Skip Fully Tipped	1 191 mm (3 ft. 91 in.)	Z	Outer Turning Circle Radius - 23.5R25	8 000 mm (26 ft. 2 in.)
K	Ground Clearance - Under Run Bar	N/A N/A	Z1	Outer Turning Circle Radius - 750/65 R25	8 029 mm (26 ft. 4 in.)

ENGINE

- Jacobs engine braking
- Dual element air cleaner with dust ejector valve
- Precleaner with automatic dust scavenging
- Water separator
- Serpentine drive belt with automatic tensioner
- Provision for fast fill

COOLING

- Crankshaft mounted electronically controlled viscous fan drive
- Fan guard

PNEUMATIC SYSTEM

- Engine-mounted compressor
- Air drier with heater
- Integral unloader valve

ELECTRICAL SYSTEM

- Battery disconnect
- Drive Lights
- Air Horn
- Reverse alarm
- Rotating Beacon
- Pitch Roll Sensor
- ▲ Artic reverse lights

STEERING SYSTEM

- Bi-directional ground-driven secondary steering pump

CAB

- ROPS/FOPS certification
- Tilt cab
- Gas strut-supported door
- I-Tip programmable dump-body tip settings
- HVAC Climate control system
- AM/FM radio/CD player
- Rear window guard
- Wiper/washer with intermittent control
- Tilt and telescoping steering wheel
- Centre-mount air-suspension seat
- Forward work Lights
- ▲ LED work lights
- ▲ Rotating beacon: seat belt installation
- ▲ Remote engine and machine isolation
- ▲ Remote battery jump start
- Retractable 3 point seat belt
- Heated seat
- Foldaway trainer seat with retractable seat belt
- 12-volt power outlet

CAB

- Cab utility bin (removable)
- Cup holder
- Cooled/heated lunch box
- Electric adjustable and heated mirrors
- Deluxe 10" colour LCD:
Speedometer / Fuel gauge /
Transmission oil temperature gauge /
Engine coolant temperature gauge /
LED function/warning indicators and audible alarm /
Transmission gear selection /
Tachometer / Battery voltage / Hour meter /
Odometer / Fuel consumption / Tip counter /
Trip timer / Trip distance / Metric/English units /
Service codes/diagnostics.
- Backlit sealed switch module functions with:
Wiper control / Lights / Heated mirrors /
Retarding aggressiveness / Transfer case differential lock /
Transmission gear hold /
Dump-body tip limit / Automatic dump-body tip settings /
Airconditioner/Heater controls /
Preselected Speed Control.

HOOK LIFT

- 3 Stage system
- Container loading and off-loading
- Container tipping

OTHER

- Automation Traction Control (ATC)
- Wet disc brakes
- Dry disc brakes
- 23.5 R 25 Radial Earthmover tyres
- Remote grease banks
- ▲ Automatic greasing
- Onboard Weighing
- ▲ Load lights: stacks
- ▲ Comfort ride suspension (Front)
- ▲ Comfort ride suspension (Rear)
- ▲ Reverse Camera
- ▲ Hand rails
- Cab Peak
- ▲ High Pressure Hydraulic filter
- ▲ Fuel Heater
- Belly cover
- Cross member cover
- ▲ Remote transmission filters

The compilation of standard and optional equipment may vary by market region. Please check with your local distributor.

All dimensions are shown in millimetres, unless otherwise stated between brackets. Under our policy of continuous improvement, we reserve the right to change technical data and design without prior notice. Photographs featured in this brochure may include optional equipment.

BELL INTERNATIONAL: Tel: +27 (0)35-907 9431

E-mail: marketing@bellequipment.com

Web: www.bellequipment.com



Tel: +61 (0)8-9355-2442



Tel: +49 (0)6631 / 91-13-0



Tel: +27 (0)11-928-9700



Tel: +44 (0)1283-712862



Tel: +33 (0)5-55-89-23-56



Tel: +7-495-287-80-02



Tel: (704) 655 2802