

NEW JCB TELEHANDLER

INDIA'S 
MATERIAL HANDLING
EXPERTS 



made in **INDIA**
for the **WORLD**



JUST WHAT YOU NEED

530-70, 530-110

Gross power: 56kW/76hp, Lift capacity: 3000kg, Lift height: 7m – 11m



Always looking for a better way

The story of JCB is one of innovation, ambition and sheer hard work. From small beginnings building agricultural tipping trailers in 1945, to the global force in manufacturing the company has become today, JCB has constantly pushed the boundaries in our desire to be the best. My father and company founder Joseph Cyril Bamford's motto was, "Jamais content", and that is exactly right – we are never content with our achievements. But I believe that even he would be amazed by what the company has become. Today, we have 22 plants on four continents and more than 750 dealers around the world.

JCB is one of the true, great British success stories.

LORD BAMFORD



40

years of
JCB TELEHANDLER



JCB TELEHANDLER

Your needs are specific, exact and absolute - which is exactly what the JCB Telehandler is built for. With a wide range of attachments customised for specific applications in various industries, the JCB Telehandler comes with an all-new global side engine design to enhance reliability, safety and comfort while delivering high productivity* at your worksite. Look for a better way with JCB Telehandlers.

*T&C Apply. Tested under controlled environment.

JCB TELEHANDLERS ACCOMPLISHING THE NEED OF CUSTOMERS ACROSS DIFFERENT INDIAN INDUSTRIES



WHY YOU NEED JCB TELEHANDLER?

THE PERFECT INVESTMENT

THE JCB TELEHANDLER IS A HIGHLY VERSATILE MACHINE WITH ADDED DURABILITY, LIFT CAPACITIES OF UP TO 3000 KG, LIFT HEIGHTS OF UP TO 11M AND A WIDE RANGE OF ATTACHMENTS. THE JCB TELEHANDLER CAN REPLACE THE NEED FOR HIRING EXTRA MACHINES SUCH AS CRANES, LOADING SHOVELS, FORKLIFT TRUCKS, SWEEPERS AND AERIAL WORK PLATFORMS.



THE WORLD'S FAVOURITE, JCB TELEHANDLER SAVES:



COST OF SPACE

Better heaping, efficient stacking.
Optimised space utilisation.



COST OF MATERIAL HANDLING

Eliminates multiple handling.
Economical operation.



COST OF OPERATION

Mechanisation of manual jobs.
High productivity.
Quicker & convenient process.



CAPITAL INVESTMENT

Leading versatility
with a wide range of attachments.
Reduced multiple machines.



PRECIOUS LIFE

Redeploys manpower to less
hazardous jobs.
Enhances on-site safety.

THE NEED FOR SUPERIOR STRENGTH & DURABILITY DELIVERED

IN ORDER TO BE TRULY EFFICIENT, OUR JCB TELEHANDLERS ARE DESIGNED TO PROVIDE YOU WITH MAXIMUM UPTIME. TO DO THAT, WE BUILD OUR MACHINES TO BE AS TOUGH AS POSSIBLE, USING HIGH QUALITY COMPONENTS AND INNOVATIVE MANUFACTURING PROCESSES. THIS, IN TURN, ENSURES MAXIMUM SERVICE LIFE.

Tough boom design.

- 1 U-shaped boom and single closing plate incorporating cats tail weld to reduce joints and stress points.
- 2 A minimum of 1m boom overlap leading to structural rigidity of the boom.
- 3 Hydraulic extension rams and ground engaging design better suited for heavy-duty bucket applications.

We've fitted a tough inverted U-shaped boom pressing with fully welded closing plates. For extra strength, we've reduced the number of joints and stress points across our integrated boom nose and one-piece closing plate.

The boom on a JCB TELEHANDLER is mounted low in the chassis, providing an extremely rigid structure and maximum over-the-shoulder visibility.



Centralised lift and displacement rams ensure load stresses are evenly distributed.



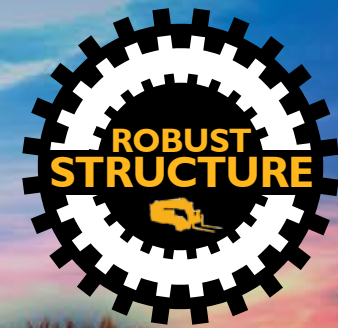

5

Durable components:

- 4 At JCB, we make our own axles, transmissions and engines – all designed to work in perfect harmony for optimum reliability.
- 5 The lift, tilt and extension rams are held in place by keyhole castings for even greater structural integrity.
- 6 Proven components- to prove how good our ecoMAX engines are, we've tested them in 70 different machines across the toughest applications and environments.*

*T&C Apply. Tested under controlled environment.



PROVEN & RELIABLE JCB DRIVELINE



4

POWERFUL ENGINE

The 76 hp high-torque engine provides productivity and maximum efficiency.

6

THE NEED OF EASE OF USE & COMFORT SOLVED

JCB TELEHANDLER OFFERS LEADING COMFORT WITH SPACIOUS CABINS, REDUCED NOISE LEVELS, BETTER AIRFLOW, VENTILATION WITH AIR CONDITIONING AND SUSPENSION SEAT FOR THE OPTIMUM DRIVING POSTURE. THE WHOLE POINT OF ANY CAB IS TO PUT THE OPERATOR IN CONTROL AND JCB TELEHANDLER DOES THIS WITH SIMPLICITY AND STYLE.

Standard cabin

- 1 Air-conditioned and well ventilated spacious cabin with a split door and rear window.
- 2 Integral LMI (Load Moment Indicator) display the load through the range, and warn the operator by visual and audio warnings in the event of the load exceeding the limit with a large easy to view inclinometer showing the machine's angle.
- 3 Smooth and ergonomically fitted control levers provide light, responsive control for precise load placement at reach or height.
- 4 Forward and reverse control are placed on the steering column for ease of access.
- 5 Comfort operator seat, tinted & laminated glass, sunblind enhance cabin comfort.
- 6 Angle roof bars for optimal visibility at height.
- 7 Gear shifting efforts reduced by 20% and gear linkage redesigned for reducing the effort force value to 4.2kg from 5.2kg.
- 8 Speedometer is changed from analogue to digital which is now more accurate.

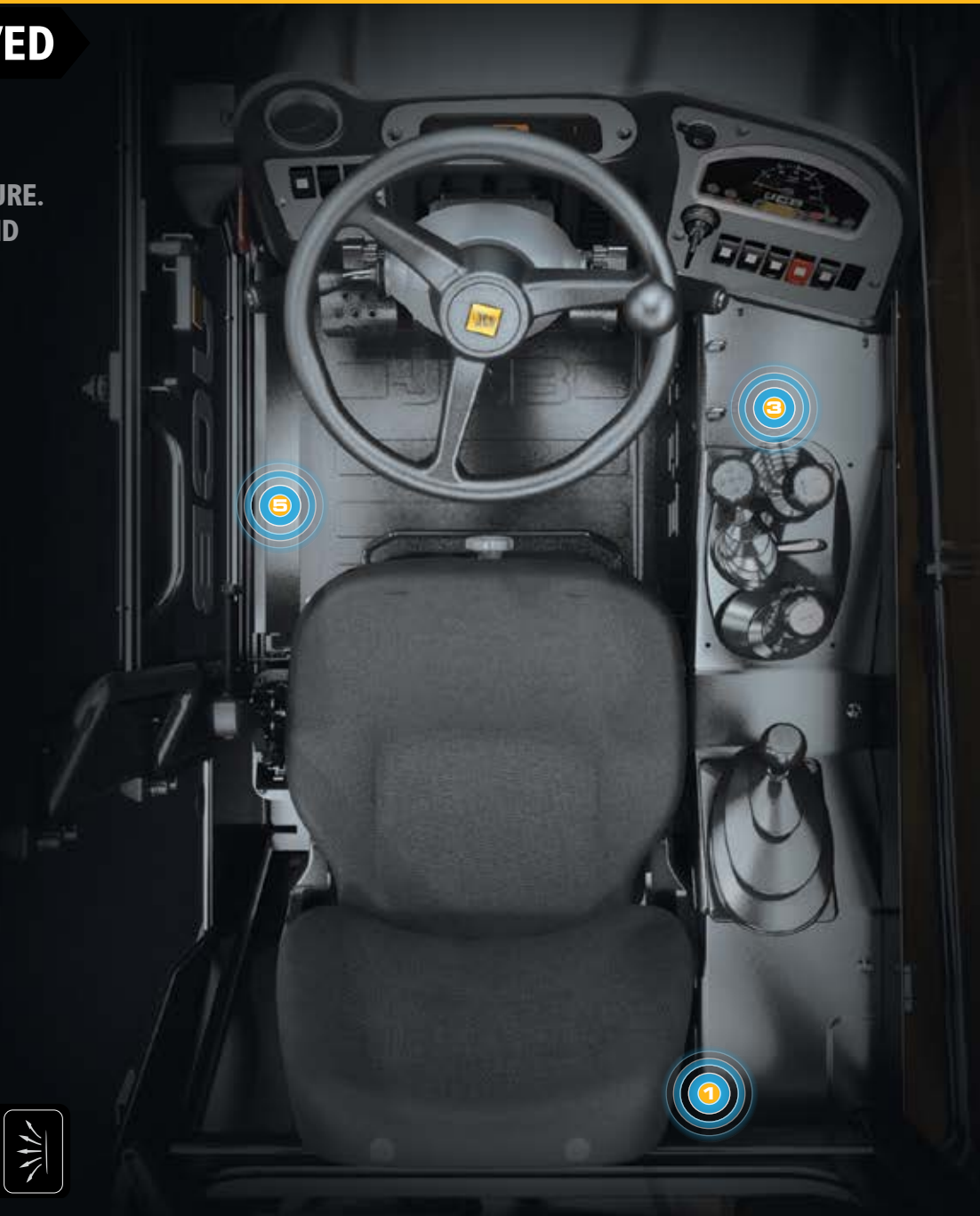

Productive controls.

9 Two-wheel steer suiting Indian working conditions which offers better operating cost and efficiency.

10 An optional reversing fan can be used to clear dust and debris from the cooling system to maintain performance.

11 Global standard side engine design with low boom mounting ensuring high all around visibility.

All around better visibility and manoeuvrability

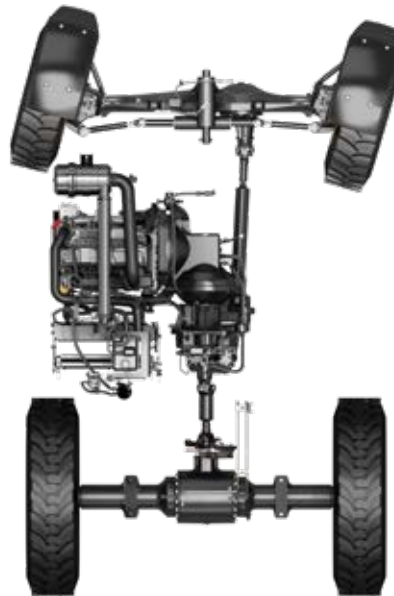

JUST WHAT IS NEEDED FOR SAFETY & SECURITY

A JCB TELEHANDLER CAN SAVE MORE THAN JUST TIME AND MONEY - IT CAN SAVE ITSELF AND ITS OPERATOR FROM POTENTIALLY DANGEROUS SITUATIONS. WE EQUIP OUR TELEHANDLERS WITH STRINGENT SAFETY MEASURES TO PROTECT FROM ACCIDENTS, AS WELL AS EFFECTIVE SECURITY TECHNOLOGY TO GUARD AGAINST THEFT.

- 1 ROPS & FOPS cabin structure for operator safety.
- 2 Stabiliser cut-off for safe working operation.
- 3 Optional hydraulic cut-off feature for operator safety to ensure machine operations within safe load capacity.
- 4 For quick, easy and safe access, JCB TELEHANDLERS have three-point access and two cab steps.
- 5 Hose burst check valves on the rams prevent collapse if a hose fails.
- 6 JCB TELEHANDLER has excellent rearward and off-side visibility, courtesy of a low boom and bonnet profile and low boom pivot.
- 7 JCB TELEHANDLER comes equipped with a full set of side and rearview mirrors for all-round visibility and safety compliance. For extra safety, a reverse alarm is standard-fit on all JCB TELEHANDLERS.
- 8 For safety, lock pin to be engaged for locking control lever, in case of operator platform.
- 9 Independent braking improves machine manoeuvrability
- 10 Angle meter on the boom, informs operator for current boom position.

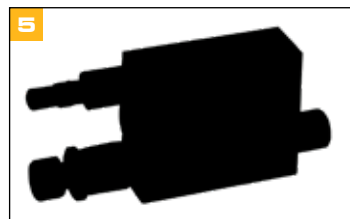

JCB Adaptive Load Control automatically controls hydraulic operation to help maintain the longitudinal stability of your JCB TELEHANDLER.

The operator presence switch on JCB TELEHANDLERS disables drive when an operator leaves the seat; this prevents accidental operation.



EXCEED THE VERSATILITY YOU NEED

Wide range of attachments: Completing the solution

- 1 For added versatility, all JCB TELEHANDLERS are fitted as standard with a single boom auxiliary feature which can power a wide range of attachments.
- 2 JCB Q-Fit system makes attachment changeover quick and easy.
- 3 Multiple control patterns are available, for different applications.
- 4 Choose from a wide array of attachments for your different needs.

Single Boom Auxiliary



Industrial fork (standard)



Width of carriage: 1.3 metre

Application: Handle palletised loads at construction sites and industries

Crane hook (standard)



Application: Lifting odd size materials

Grain bucket*



Capacity: 2 cum

Width: 2.3 metre

Application: Low-density material handling

Coal bucket

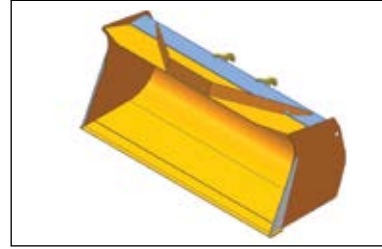

Capacity: 2 cum

Width: 2.3 metre

Application: Low-density material handling with more strengthening

Truck unloading bucket



Capacity: 0.9 cum

Width: 1.8 metre

Application: To unload loose material from trucks

Bucket with grab*



Capacity: 1.2-1.3 cum / 1.6-1.7 cum

Width: 1.8 metre / 2.3 metre

Application: General material handling

Sugarcane grab



Capacity: 0.3 cum

Width: 1.8 metre

Application: Best suitable for grabbing and carrying material

Round bale clamp*



Capacity: 1100 kgs

Width: 1.6 m

Application: To handle round bales

Power grab



Capacity: 1.6 cum

Width: 2.3 metre

Application: General material handling / sugarcane handling

Narrow industrial fork*



Width of carriage: 1 metre

Application: Handle palletised loads in confined areas and narrow spaces

Options: Narrow fork with roller and side shift fork are also available.

Heavy-duty fork



Width of carriage: 1.8 metre

Application: To handle & unload shredded material from trucks

Grain pusher



Length: 3.3 metre

Application: Stacking or heaping of loose material

Unloading rake



Length: 17 ft

Width: 1.5 metre

Application: Unloading material from the trucks

Drum handler



Application: Drum handling

Man platform



Capacity: 450 kgs

Width: 2.5 metre

Application: Maintenance or work at height

TOTAL CONTROL, TOTAL PRODUCTIVITY

JCB LIVELINK - AN ADVANCED TELEMATICS SYSTEM THAT LETS YOU MANAGE YOUR JCB MACHINES REMOTELY - ONLINE, BY EMAIL OR BY MOBILE PHONE. GET COMPREHENSIVE INSIGHTS ON YOUR MACHINE, FROM HEALTH ALERTS TO SECURITY ALERTS, WITH ALL DATA STORED AT A SECURE CENTRE.



Security

-  In case of sudden drop in fuel level get an SMS/e-mail alert.
-  Alerts you via SMS/e-mail in case the machine is used outside the set hours.
-  Helps to locate your machine precisely on the map to display its current location.
-  Get SMS/e-mail alerts in case the machine moves out of the geofenced area.
-  Alerts you via SMS/e-mail in case the machine is being towed away even in engine off condition.

Proactive maintenance & usage

-  Maintenance reminders.

Operation & performance monitoring

-  Machine usage can be monitored in detail including the hours worked in each mode.
-  Instantaneous fuel level monitoring.

Reports & alerts

-  Customised reports on performance, utilisation, fleet summary, landmark activity, machine hours and service status.
-  Easier fleet management.
-  Periodic reports - Daily, weekly, monthly or as required.
-  Machine status and critical health alerts.

Safety

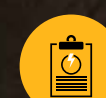
-  Engine high rpm shut-down report: Know the number of times the engine shuts down while working at high speeds.
-  Long engine idling report: Know the number of times the machine idles for a long time, minimising idle hours and saving fuel.



EASY ACCESS & SERVICEABILITY

NATURALLY, YOU WANT YOUR JCB TELEHANDLER TO SPEND AS MUCH TIME AS POSSIBLE AT WORK, NOT BEING WORKED ON. WHICH IS WHY JCB TELEHANDLERS HAVE LONG SERVICE INTERVALS; AND, WHEN MAINTENANCE DOES NEED TO BE CARRIED OUT, YOU'LL FIND OUR MACHINES ARE EASY AND QUICK TO SERVICE.

- 1 All daily checks, greasing and serviceable components can be accessed at ground level.
- 2 Battery is easily accessible via a lockable cover that is opened with the ignition key.
- 3 The diesel tank is easy to reach and can be filled from ground level.
- 4 Dry lubricant system - TELEHANDLER's wear pads are extremely durable, with service intervals of 500 hrs.
- 5 The filters on a TELEHANDLER (engine oil, hydraulic oil and fuel) are centrally located for fast, better SAE serviceability ratings.
- 6 Tilttable cooling pack for easy clean in highly dusty condition.
- 7 Optional turbo 3 pre-cleaner & reversible fan to ensure maximum operation hours in extreme dusty & choking applications.
- 8 Exhaust scavenging enhances air cleaner life.
- 9 Service interval enhanced to 500 hrs.
- 10 Split type engine pad for better access in engine.





WE ARE CLOSER TO YOU

JCB EXCEEDING EXPECTATIONS
EVERYWHERE
CUSTOMER SUPPORT

Construction Equipment industry's extensive customer support network

 **65+**
Dealers

 **700+**
Outlets

 **5,000+**
Trained service
engineers

 **5**
Parts warehouses

 **3,000+**
Mobile service
engineers

 **4**
Training centres

 **250+**
Service vans

 **24x7**
Support
12 Languages



EXTENDED CARE

GIVE YOUR MACHINE EXTENDED WARRANTY AND CARE.

- JCB Careplus is an extended warranty programme that comes into effect after the machine standard warranty expires.
- JCB Careplus can be purchased within the 1st year from the sale of the machine.
- The programme offers you peace of mind and saves your maintenance cost even after your machine standard warranty expires.



Extended
Warranty
Programme



BENEFITS OF JCB CAREPLUS



No limits on number of claims



Preventive maintenance service*



Nationwide coverage**



JCB skilled manpower support



Maximum productivity



Maximum uptime



Maximum performance



Breakdown cost protection



Better resale value

*Varies on JCB Careplus package selected.

**All services completed in line with the JCB recommended service interval schedule.

JCB LOYALTY PROGRAMME



with you always...

We believe that customer loyalty is paramount to any brand's success. Our loyalty programme is a reflection of our brand promise and our constant endeavour to offer you more than your expectations.

Instant membership card | Welcome kit
Rewards points | Extended benefits
Special programme features

Blue Card



On purchase of a new machine or parts worth ₹1,000

Silver Card



Blue members making a purchase of ₹25,000 in the quarter

Gold Card

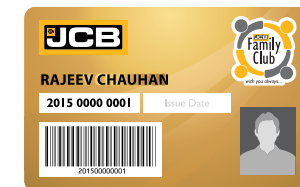

Silver members making a purchase ₹50,000 in the quarter

SMART & DIGITAL SUPPORT

Assured parts supply

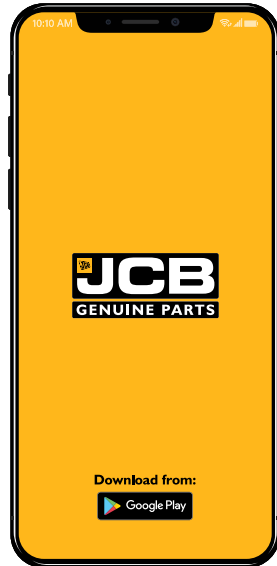

JCB in India have built a robust logistics and supply management chain across the country that facilitates the provision of parts for all machines in the shortest time. Customers can now get JCB genuine parts easily and conveniently through its mobile app.

Download from:



Smart Serve

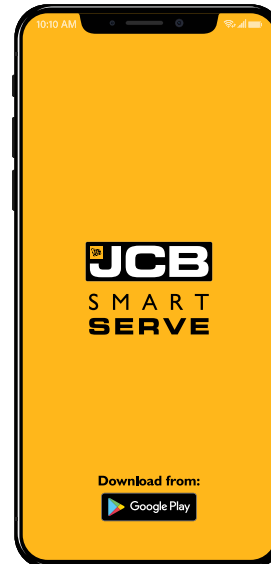

Our service engineers are equipped with Smart Serve technology which enables JCB to send the nearest engineer to the machine, ensuring maximum uptime.

Upgraded connect



Be assured of your JCB machine's service, operation and security parameters with the advanced telematics system - LiveLink and now with the all-new LiveLink mobile app, monitor your machine anytime, anywhere with just a touch.

Download from:



EXTENSIVE PARTS SUPPORT



Our wide range of JCB attachments complete your machine's performance with maximum efficiency and productivity and thus reduce downtime and increase more savings.

- Value for money
- Perform in synergy with multiple products
- Maximise your machine's performance
- Demonstrate exemplary durability & reliability



Being compatible with the JCB machines, the range of JCB lubricants assure a 100% better life for all your JCB genuine parts.

- JCB lubricants meet JCB specifications
- JCB lubricants are specially formulated as per JCB specifications
- High-quality base oils blended with very high-quality additive packages
- Peak performance in hazardous condition due to the following reasons:
 - Maintains viscosity at higher temperature and pressure
 - Load carrying capacity
 - Oxidation stability
 - Dispersant
- Complete equipment protection



JCB genuine parts offer a comprehensive machine protection solution. Designed to work in conjunction with JCB fluids in the JCB engines in synergy with other component systems, ensuring:

- Optimum flow and system efficiency
- Maximized engine performance
- Reduced running costs
- Compliance with emissions norms
- Protection from system contamination

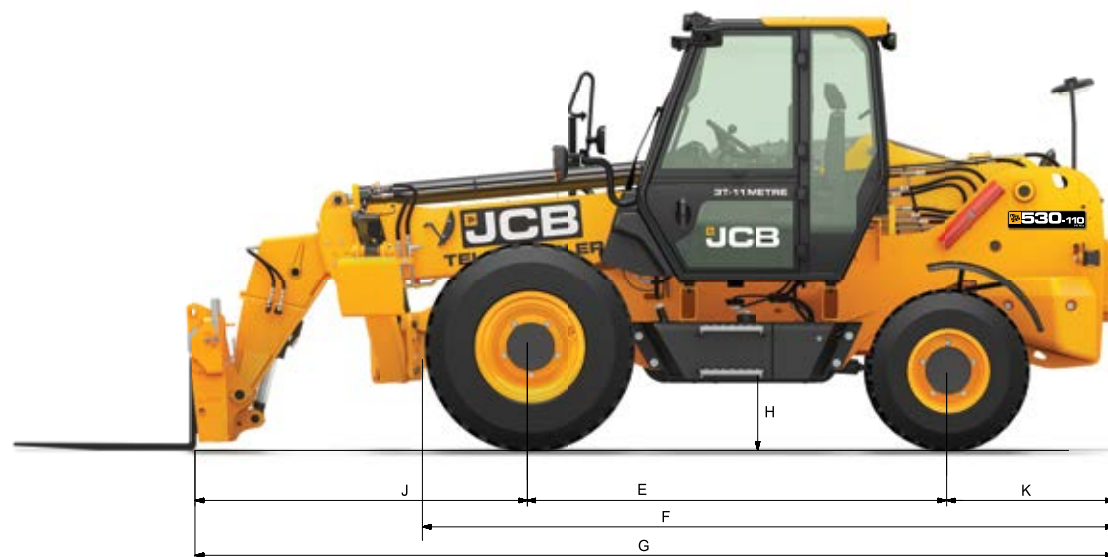

**STATIC DIMENSIONS- Dimension - m**

Parameters			530-70	530-110
A	Overall height	m	2.62	2.62
B	Overall width (over tyres)	m	2.36	2.36
C	Inside width of cab	m	0.79	0.79
D	Front track width	m	1.99	1.99
E	Wheelbase	m	2.54	2.54
F	Overall length to front tyres	m	4.13	4.13
G	Overall length to front carriage	m	4.92	5.43
H	Ground clearance	m	0.39	0.39
J	Front-wheel centre to carriage	m	1.42	1.93
K	Rear wheel centre to rear face	m	0.95	0.95
	Operating weight	kg	7154 (with Fork)	9060 (with Fork)
	Outside turn radius (over tyres)	m	4.85	4.85
			Bucket rollback angle (at full height) 37 deg.	Overall width with stabilisers fully deployed 2.65 m
			Bucket dump angle (at full height) 44 deg.	Fork rollback angle (at full height) 7.5 deg.

* All dimensions, weights and timings are variable within 1.5%. JCB reserves the right to change specifications without prior notice.

LIFT PERFORMANCE

JCB TELEHANDLER 530-70 | SPECIFICATION

Operating weight : 7154 kg Max. payload : 3 tonnes Max. lift height : 7 metres

JCB TELEHANDLER 530-110 | SPECIFICATION

Operating weight : 9060 kg Max. payload : 3 tonnes Max. lift height : 11 metres

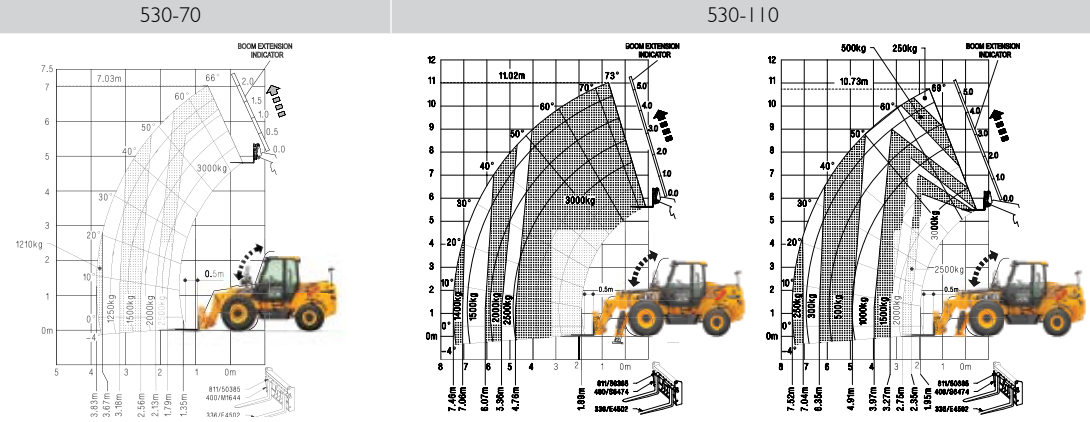

			530-70		530-110	
					With stabilisers extended	With stabilisers retracted
Maximum lift capacity	kg		3000	3000	3000	
Lift capacity to full height	kg		2500	3000	250	
Lift capacity at full reach	kg		1210	1400	250	
Lift height	m		7.0	11.0	10.73	
Reach at maximum lift height	m		1.0	0.9	1.5	
Maximum forward reach	m		3.83	7.46	7.52	
Reach with 1 tonne load	m		3.83	7.46	4.91	
Placing Height	m		6.3	10.5	10.25	



ENGINE

JCB 448, naturally aspirated 4 cylinder, water cooled with EGR Cooler diesel engine
 Displacement: 4.8 L
 Gross power: 56 kW (76 hp) @ 2200* rpm
 Max torque: 310 Nm (31.6 kgm) @ 1100 rpm
 *Operating RPM 2250

TRANSMISSION

JCB 4WD synchroshuttle transmission. 4-speed fully synchromesh gearbox with integral torque converter and electrically operated forward - reverse shuttle.

- Easy to use, column mounted electric switch allows operator to change machine direction while in motion without taking his hands off the steering wheel. This leads to safe and efficient operation and cycle times.
- The pedal layout and conventional 4-pattern gear lever with transmission switch adds to the overall ease of operation.
- Torque converter stall ratio 3.01:1.
- 4WD can be selected at any time on the move with a simple electric switch.
- Additional transmission dump provided on loader lever, to help disengaging transmission in need of higher hydraulic power demand.

AXLES

Front axle:

JCB drive axle rigidly mounted incorporates JCB max-track torque proportioning differential, driven by propeller shaft from gearbox.

Rear axle:

4WD steer drive axle centrally pivoted with oscillation angle of 16°, driven by propeller shaft from gear box.

BRAKES

Service: Hydraulically actuated, dual line, self adjusting, compensated oil immersed, multi-disc type on the front axle, operated through independent pedals, linked together for normal use. Two independently operating foot pedals enable machine to manoeuvre in tight spaces.

Parking: Hand operated cable actuated disc brake mounted on front axle input disc and additionally transmission dump.

STEERING

- Rear wheel hydrostatic power steering with manual capability in the event of engine or hydraulic power failure.
- Inner angle 38° & Outer angle 30°

ELECTRICALS

- 130 Ampere-hour, 12 Volts battery system with alternator and full road lighting.
- Dust and waterproof IP69 electrical connectors.

TYRES

Front : 13.00 x 24 -16PR
 Rear : 12.5 x 18 -12PR Industrial traction pattern tyres
 Tyres Option : HD Tyres / Extra HD Tyres / Solid Tyres / Agri Tyres

SPEED

Maximum road speed : 30 km/hr

SERVICE CAPACITIES

Fuel tank	110 L
Hydraulic tank	120 L
Engine coolant	16.5 L
Engine oil	14.2 L
Transmission	18 L
Front axle	21 L
Rear axle	11 L

OPTIONS & ACCESSORIES

- Windscreen & Roof Guard
- Rear Grill Guard
- Spark Arrestor
- Boom & Rear Working Lights
- Hydraulic Cut-off
- Dome Mirror
- LiveLink
- Fire Extinguisher
- Reversible Fan
- Tool Kit
- Grease Bucket
- Rear View Camera

CABIN

- Conform to ROPS ISO 3471 & FOPS ISO 3449 tinted & laminated cab glass provides excellent all round visibility & sun protection.
- A fully adjustable seat with seat belt combined with ergonomically positioned controls and soft touch steering wheel maximise operator output.
- Large convex rear view mirror, interior light, front screen wiper, front and rear horn, hazard warning system and tool box.
- Instrumentation panel includes engine speed, engine hours, fuel level, water temperature and 12V socket for mobile charger.
- Longitudinal load moment Indicator (LLMI) & inclinometer to provide warnings on machine stability.
- 2 speed full ducted AC unit in cabin.

HYDRAULICS

	530-70	530-110
Pump	2 Section Gear	
Pump capacity	103 lpm	
Main relief valve	(245 bar) 24500000 Pa	
Hydraulic cycle times	Seconds	
Boom up	9.9	11.3
Boom down	7.9	9.2
Extend	5.9	14.7
Retract	3.7	19.7
Bucket dump	3.4	3.0
Bucket crowd	2.8	2.4

- Filtration through suction strainer and return line 'JCB filtromatic filter'.
- During lifting, the circuit automatically adjusts the pump flow to provide more power for lifting operation.

LIVELINK

Advanced telematics system that enables you to monitor and manage your machines remotely by providing information on :

Service : Routine maintenance information and alerts

Operation : Health alerts and usage data

Security : Machine location & movement data

EARLY ADOPTERS OF THE CONCEPT

JCB Telehandler is a versatile machine that roars great functionality at all times.

We needed a highly flexible and versatile machine for offloading jobs at our sites. After surfing through the internet and witnessing demonstrations organized by JCB team, we finally decided to buy a JCB Telehandler for all those jobs.

Our association with JCB is just a year old and we already feel that it's going to get better in the times to come. With a JCB Telehandler, the attachments come as an added advantage. They enable the machine to adapt quickly and work as per the requirement.



Chirag Desai
Sunalco Alloys Pvt. Ltd.

We thank JCB for making innovation a reality in the construction equipment industry.

We are in the business of making specialized paper with a production capacity of 55,000 tonnes per annum. Our main raw materials are imported wood pulps and waste paper. We also have heaps of coal stored at our plants for steam generation and energy production, which is done on 24 hours basis for uninterrupted production.

For us, the need of the hour was to have all materials available at the right place and at the right time for continuous productivity. After our bit of research, we decided to invest our money in JCB Telehandler.



N.V. Gune
Pudumjee - Pulp & Paper Mills, Pune.

Thanks a lot to JCB for introducing such a versatile machine for the Indian markets.

I work as a Site in-charge with Max Infra Pvt. Ltd., Hyderabad. For the T5 Srinagar - Baramula Rail Tunnel Project we only had JCB Backhoe Loaders and were using other JCB products at various other sites. At the same time, we were searching for a telescopic category of machine and found various information and videos about the category over the internet. One of the most promising was about JCB Telehandler.

We asked for a few details from the nearest JCB dealer in our area and found Telehandler to be a perfect choice for our tunnel project. We finally bought a JCB Telehandler along with four attachments; a crane hook, shovel, man basket and fork.



Rajeev Pathania
PT5 Srinagar - Baramula Rail Tunnel Project,
Max Infra Pvt. Ltd., Hyderabad.

This machine has been a revolutionary product and we would like to thank JCB for such a great engineering display.

Our company is into manufacturing of nano vitrified tiles and glazed vitrified tiles. We have been associated with JCB from the past 2 years. Out of the two machines we have, one is a JCB Telehandler and we are reaping great benefits from this marvel. Earlier, the manpower at our site used to take 5 - 6 hours for completion of the job but now thanks to this engineering marvel, our job is completed within an hour. We basically have 3 main applications to be done at our site - Hopper feeding, loading & heaping, and all the work is done by JCB Telehandler single-handedly.

Our production has increased by 10%, with the help of JCB Telehandler, from production of 5000 boxes a day, we have reached to 6000 boxes a day. The Powerful AC Cabin ensures a fatigue operation and operators now are even willing to work overtime.



Ketu Bhai Himani
Finstone Granite - Director



World's No. 1

An aerial photograph of a quarry or construction site. A yellow JCB telehandler is in the foreground, its boom extended and bucket raised, dumping a load of grey gravel into the bed of a blue truck. The truck is parked on a large pile of gravel. In the background, another piece of heavy machinery is visible, and the ground is covered in tracks and piles of material. The scene is brightly lit, casting shadows on the gravel.

Telehandler



ONE COMPANY, OVER 300 MACHINES.

Dealer's stamp:

JCB INDIA LIMITED 23/7 Mathura Road, Ballabgarh - 121 004 Haryana, India. Fax: 91 129 2309050
 For more information SMS "JCB" to **56767** or call our toll free no. **1800-1037-386**
 Website: www.jcb.com

Follow us: [f](#) [t](#) [v](#) [i](#) [i](#) /JCBIndiaLtd

©2009 JCB Sales. All rights reserved. No part of this publication may be reproduced, stored in a retrieval system, or transmitted in any form or by any other means, electronic, mechanical, photocopying or otherwise, without prior permission from JCB Sales. All references in this publication to operating weights, sizes, capacities and other performance measurements are provided for guidance only and may vary dependant upon the exact specification of machine. They should not therefore be relied upon in relation to suitability for a particular application. Guidance and advice should always be sought from your JCB Dealer. JCB reserves the right to change specifications without notice. Illustrations and specifications shown may include optional equipment and accessories. The JCB logo is a registered trademark of J C Bamford Excavators Ltd.

