



## BACKHOE LOADER | 3CX

Gross power: 68.6kW (92hp) Maximum dig depth: 5.46m Maximum loader shovel capacity: 1.1m<sup>3</sup>



## INTRODUCING THE JCB 3CX.

COMBINING LOW COST OF OWNERSHIP, SUPERIOR STRENGTH AND INNOVATIVE FEATURES GALORE, THE JCB 3CX IS ANOTHER GREAT VALUE MACHINE FROM THE WORLD'S NUMBER ONE BACKHOE MANUFACTURER. PRODUCTIVITY, PERFORMANCE AND EFFICIENCY ARE ALL CLASS-LEADING, MAKING THIS A PERFECT SOLUTION FOR LARGE FLEETS, RENTAL YARDS AND SMALLER BUSINESSES ALIKE.



### The world's number one.

Market leader in 74 countries, around half of all the backhoe loaders sold in the world today are JCBs.

### Value for money.

Our entry-level 3CX is a great value machine, boasting low cost of ownership and superior strength as standard.

### Innovation built in.

This machine packs the sort of innovative features that make JCB backhoes synonymous with class-leading productivity, performance and efficiency.

### Strength in depth.

There's durability aplenty throughout to cope with the rigours of the rental industry.

### Low maintenance engine.

JCB DIESELMAX is a highly efficient 68.6kW Tier 2 compliant engine, this keeps servicing and refuelling costs low.

### Excellence in any field.

The 3CX is the number one go-to solution for large fleets, rental yards and owner operators alike.

As global market leader, JCB sells around half of all the world's backhoe loaders.





## COST OF OWNERSHIP AND EFFICIENCY.

WE UNDERSTAND THAT A LOW COST OF OWNERSHIP IS ESSENTIAL IN TODAY'S COMPETITIVE WORLD. WHETHER YOU RENT OR OPERATE YOUR FLEET, THE JCB 3CX IS DESIGNED TO GIVE YOU ULTIMATE VALUE FOR MONEY.

### Maximum return on investment.

**1** The JCB 3CX is a great value entry level machine offering superb return on investment as well as affordable insurance, finance and service parts.

**2** Unlike most entry level backhoes, this is an extremely efficient machine. JCB's DIESELMAX engine is very powerful and offers excellent fuel economy by producing high torque at low revs.

DIESELMAX is a highly durable engine design, with tens of thousands of units in service all over the world working on a huge range of different applications.

**3** The 3CX has a top speed of 40kph so you can reduce travel times on site and between locations.

**4** With high breakout forces you'll be able to shift more material in less time. Put simply, these are the most efficient loaders in their class.



**2**



**1**



**3**



**4**

# QUALITY, RELIABILITY AND DURABILITY.

WHATEVER YOU HAVE IN STORE FOR YOUR BACKHOE LOADER FLEET, YOU'RE SAFE IN THE KNOWLEDGE THAT THE JCB 3CX IS BUILT TO WITHSTAND ANYTHING. STRUCTURAL PARTS ARE UNCOMPROMISINGLY TOUGH, AND KEY COMPONENTRY IS WELL PROTECTED FROM HARM.

Each key component of the latest JCB backhoe range is stringently tested. The chassis, boom, loader arms and other major parts are all subjected to prolonged high-stress loading, while the transmission design has been repeatedly put through its paces over thousands of cycles.



1

## Designed and built by JCB.

1 The cabs, axles, transmissions and engines are all designed and built by JCB. All components therefore work in perfect harmony for optimum reliability.

2 We use state of the art manufacturing processes like robot machining, precision paint technology and innovative assembly techniques to achieve the highest levels of quality.



2

## Tested to the limits.

3 To ensure maximum reliability, we've tested our DIESELMAX engine rigorously in climates ranging from -18°C to 46°C with a grid heater fitted.

Fluorescent dye is added to the hydraulic oil so we can accurately identify any potential leaks during testing.



3





By heating the boom and dipper to 650 °C, we remove any internal stresses caused by manufacturing and welding. This process doubles the life of our booms and reduces the overall machine weight at the same time.



**Built to last.**

- 6 JCB precision machining provides high tolerances and accurate location of pins and bushings.
- 7 The hydraulic cylinders have friction welded ends to give extra strength.
- 8 We use a powder coat paint process which provides a high quality finish. Paint coverage is optimised and your machine stays looking good for longer.

**Protected from damage.**

- 9 To protect boom and dipper hoses from the perils of trenchwork, we've enclosed them inside the rear structures of the machine.
- 10 Kingpost hoses, meanwhile, are enclosed in a flexible, robust guide to keep them from snagging or sustaining damage.

The steering cylinders are positioned high up behind the front axle which provides additional protection when moving over arduous ground.

Both cab and canopy machines are ROPS/FOPS certified for excellent operator protection from roll-over and falling objects.



## PRODUCTIVITY AND PERFORMANCE.

THE JCB 3CX IS DESIGNED TO OFFER YOU ULTIMATE PRODUCTIVITY – WHICH OF COURSE EQUATES TO ULTIMATE VALUE-FOR-MONEY. PERFORMANCE IS BEST-IN-CLASS AND SO IS THE MACHINE'S STANDARD SPECIFICATION.

### A more productive backhoe.

The JCB DIESELMAX engine produces its peak power and torque at low engine speeds, which makes for exceptional responsiveness, great economy and outstanding performance.

- 1 Select our optional Extradig package with an innovative inner box design to give you an extra 1.2m of reach and dig depth. That means less repositioning and, of course, more efficiency.
- 2 The boom and dipper are of equal length, this allows digging close to the machine, meaning less repositioning, thus saving fuel.
- 3 A large 128 litre fuel tank extends refuelling intervals and maximises productivity.
- 4 This backhoe excels in both uneven terrain and confined spaces thanks to a winning combination of high ground clearance and an excellent turning circle.
- 5 There's a powerful slew to ensure fast and controllable backfilling.



To guarantee ultimate performance in all conditions, the 3CX is equipped with 4WD as standard, and has a top speed of 40kph.





### Lifting standards.

**6** Load retention is exceptional with the 3CX's 45° loader shovel rotation.

Best in class loader shovel break out forces gives exceptional breakout ability improving loading times.

Reduce downtime during attachment changes by choosing our mechanical rear quickhitch option.

Optional Limited Slip Differential provides automatic traction control to enable the machine to drive in the toughest of conditions and enables the machine to still steer unlike differential locks designs.

**7** JCB's highly versatile 6-in-1 shovel is compatible with the 3CX backhoe, meaning that operators can dig, doze, load, grab, grade and backfill with just one tool.

**8** Excellent forward reach enables the machine to easily load high sided trucks.

**9** You can easily operate high powered attachments like breakers and patch planers courtesy of a high performance hydraulic pump.

**10** Large 28" wheels give excellent stability when working on uneven ground.



## SERVICEABILITY.

WE'VE MADE SURE THE JCB 3CX WILL PROVIDE MAXIMUM UPTIME BY VIRTUE OF BEING INCREDIBLY EASY TO SERVICE. ROUTINE MAINTENANCE IS STRAIGHTFORWARD, DAILY CHECKS COULDN'T BE SIMPLER, AND THERE'S PLENTY OF GROUND-LEVEL ACCESSIBILITY.

### Easier routine servicing.

**1** All of the 3CX's daily checks and routine servicing can be done from one side of the machine. Important service items are grouped, too, for improved access and improved productivity.

**2** The bonnet is a one-piece unit, and opens easily without having to remove extra panels.

**3** Greasing and refuelling can both be done from ground level, making them easy tasks to carry out on a 3CX.

Livelink comes as standard\* for improved serviceability and maintenance planning through service alerts and other notifications.

**4** We've made the battery on this backhoe very easy to access and replace.

SERVICE INTERVALS	
Engine oil	Every 500 hours
Engine oil filter	Every 500 hours
Hydraulic oil	Every 2000 hours
Hydraulic oil filter	Every 500 hours
Transmission oil	Every 500 hours
Transmission filter	Every 500 hours
Axle oil	Every 1000 hours



\*Regional dependent.



We've fitted additional fuel filtration to reduce dirt in fluids and prevent blockages.

### Minimizing downtime.

- 5 A lockable front grille safeguards the battery and isolator, eliminating potentially costly theft-related downtime.
- 6 There's no time-consuming dust bowl or precleaner to maintain on this machine, saving precious operator time and improving forward visibility. What's more, our scavenge design discharges dirt through the exhaust to extend air filter life.
- 7 The large 85 litre hydraulic tank is mounted outboard for easy access and improved cooling, therefore improving life span of oil.
- 8 Hydraulic hoses all meet at the bulkhead manifold, meaning that replacement is straightforward.
- 9 Exceptional ground clearance (best-in-class) enables the machine to drive over difficult terrain and reduces costly damage to the underside of the machine.





## COMFORT AND EASE OF USE.

ANOTHER IMPORTANT CONTRIBUTOR TO PRODUCTIVITY IS COMFORT – AFTER ALL, A COMFORTABLE OPERATOR IS A PRODUCTIVE ONE. ACCORDINGLY, THE JCB 3CX IS DESIGNED FOR DAY-LONG OPERATOR COMFORT.

### A great place to work.

Our cabs are pressurised to ensure a clean and controlled working environment. A canopy variant is also available\*.

- 1 To create the perfect working environment for operators – and, in turn, improve productivity – air conditioning comes as standard\* on enclosed cab machines.
- 2 To enable longer working stints, the 3CX boasts a low effort braking setup.
- 3 There's a 12V auxiliary circuit in the cab so that operators can charge phones and use various accessories.
- 4 Our fully adjustable suspension seat comes as standard, providing operators with improved comfort and reduced fatigue for longer working stints.
- 5 Lockable storage aplenty, with work tools easy to accommodate even if you choose the canopy option.

Operating the 3CX is straight forward; the traditional manual control system is easy and comfortable to operate.



\*Regional dependent.



## SAFETY AND SECURITY.

SAFETY IS OF PARAMOUNT IMPORTANCE ON ANY SITE, SO THE JCB 3CX HAS PLENTY OF FEATURES TO PROTECT ITSELF, ITS OPERATORS AND BYSTANDERS ALIKE.

### Safety first.

**1** Getting in and out of a JCB 3CX is easy and safe courtesy of large anti-slip steps with an open grille design to prevent material build-up. Not only that but there are always three points of contact available to an operator when entering and exiting the machine.



**2** With a laminated front screen and toughened flat glass everywhere else, operator safety is optimized, including during powered attachment use. If a piece of glass does need replacing, this can be done quickly and easily to minimize downtime.

Four cylinder geometry means the shovel cylinders are in line with the loader arms providing best-in-class forward visibility.

**3** The rear boom lock ensures safety when roading. The cable operated boom lock stops removable pins from being lost.



**4** Self levelling loader ensures the load is always kept safe, especially when using forks to prevent material spillage.



In a JCB 3CX, operators sit higher up than in most construction machinery. This viewpoint provides excellent visibility through 360° of the working area.



# LIVELINK, WORK SMARTER.

**LIVELINK IS AN INNOVATIVE SOFTWARE SYSTEM THAT LETS YOU MANAGE JCB MACHINES REMOTELY – ONLINE, BY EMAIL OR BY MOBILE PHONE. ACCESS USAGE OF A MACHINE WITH DATA STORED AT A SECURE CENTRE.**

## Productivity and cost benefits

By providing information on hour usage JCB Livelink helps to monitor and improve productivity. Machine location information can help improve efficiency and perhaps even reduce insurance costs.



## Maintenance benefits

Manage machine maintenance easily – accurate hours monitoring and service alerts improve maintenance planning, while real-time location data helps you manage your fleet.



## Security benefits

Livelink's real-time geofencing alerts tell you when machines move out of predetermined zones, and real-time curfew alerts inform you of unauthorised usage. Further benefits include real-time location information.

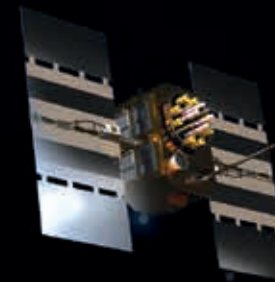



## VALUE ADDED.

JCB'S WORLDWIDE CUSTOMER SUPPORT IS FIRST CLASS. WHATEVER YOU NEED AND WHEREVER YOU ARE, WE'LL BE AVAILABLE QUICKLY AND EFFICIENTLY TO HELP MAKE SURE YOUR MACHINERY IS PERFORMING TO ITS FULL POTENTIAL.



**1** Our Technical Support Service provides instant access to factory expertise, day or night.

**2** The global network of JCB Parts Centers is another model of efficiency; with 16 regional bases, we can deliver around 95% of all parts anywhere in the world within 24 hours. Our genuine JCB parts are designed to work in perfect harmony with your machine for optimum performance and productivity.



**3** JCB Assetcare offers comprehensive extended warranties and service agreements, as well as service-only or repair and maintenance contracts. Irrespective of what you opt for, our maintenance teams around the world charge competitive labour rates, and offer non-obligation quotations as well as fast, efficient insurance repair work.

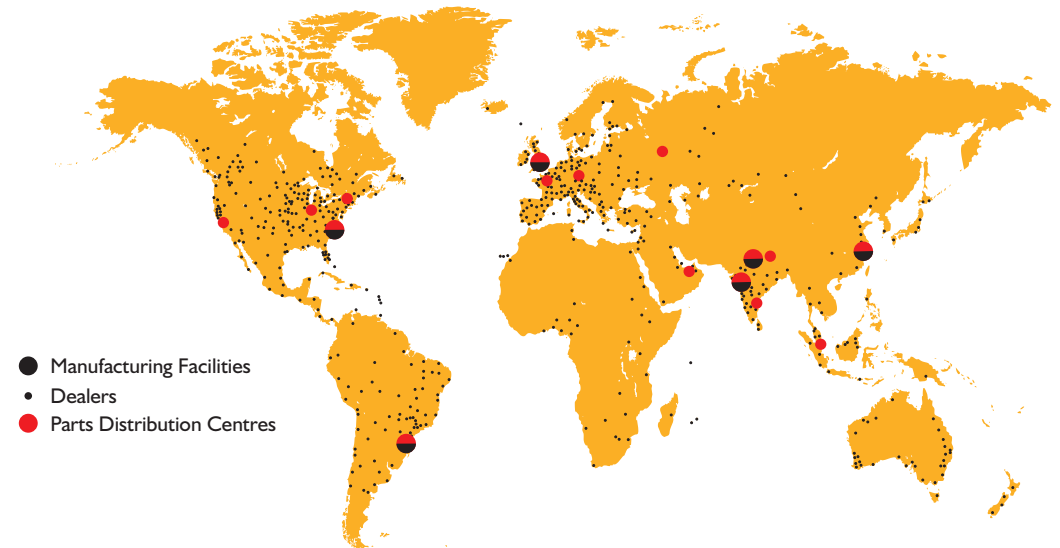

Note: JCB ASSETCARE may not be available in your region, so please check with your local dealer.

# THE OPTIONS LIST.

THE JCB 3CX IS A VERY VERSATILE MACHINE AS STANDARD, BUT IT'S EVEN MORE FLEXIBLE AND PRODUCTIVE WHEN YOU START TO EQUIP IT WITH OUR FACTORY-APPROVED OPTIONAL EXTRAS.

## 6-in-1 loader shovel.

**1** Dig, doze, load, grab, grade and backfill using just this one incredibly versatile tool.

## Quickhitch options.

**2** Our mechanical excavator quick coupler makes attachment changing much quicker for improved productivity.

## Heavy-duty bucket.

**3** Extra ribbed plates provide extra strength and reduce wear when you're working with harder material.

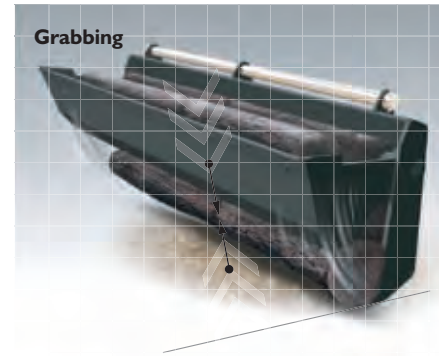
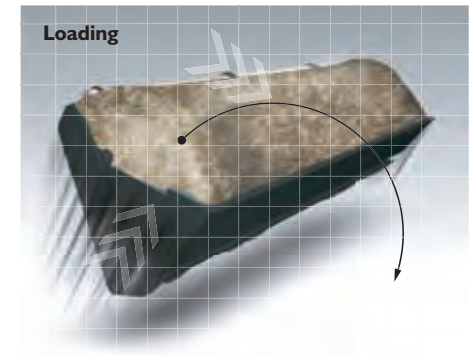
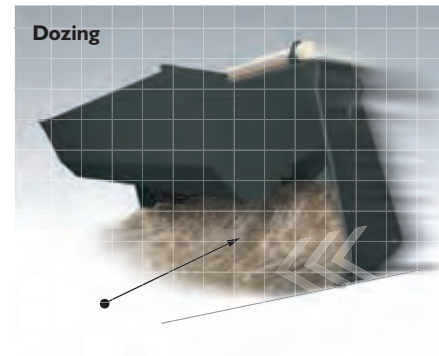



## STATIC DIMENSIONS

Loader end max. payload: 1850kg (4078lb) Max. lift height: 3.23meters (10.59ft)

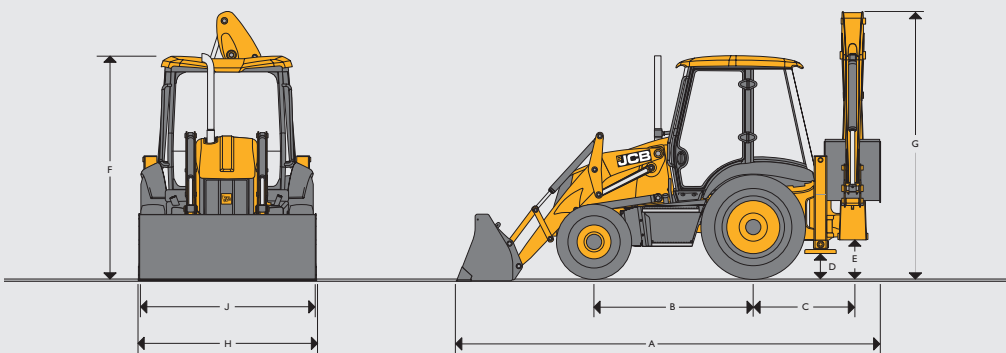

		4WD
A	Total travel length	m 5.62
B	Wheelbase	m 2.17
C	Slew centre to rear axle centre	m 1.36
D	Minimum ground clearance (stabiliser foot clearance)	m 0.36
E	Slew ground clearance	m 0.53
F	Cab roof height	m 2.89
G	Total travel clearance	m 3.61
H	Shovel width	m 2.23 (6-in-1 shovel) / 2.35 (GP shovel)
J	Rear frame width	m 2.35

## ENGINE

Manufacturer		JCB
Aspiration		Turbocharged
Displacement	liter	4.4
No. of cylinders		4
Bore	mm	103
Stroke	mm	132
Rated engine	rpm	2200
<b>Power ratings</b>		
Gross HP – SAE J1995 (ISO 14396)	kW (hp)	68.6 (92)
<b>Maximum torque</b>		
Rated ISO 14396 (SAE J1995)	Nm (lb ft)	400 (295)
Max. Torque	rpm	1400

## EXCAVATOR/LOADER PERFORMANCE

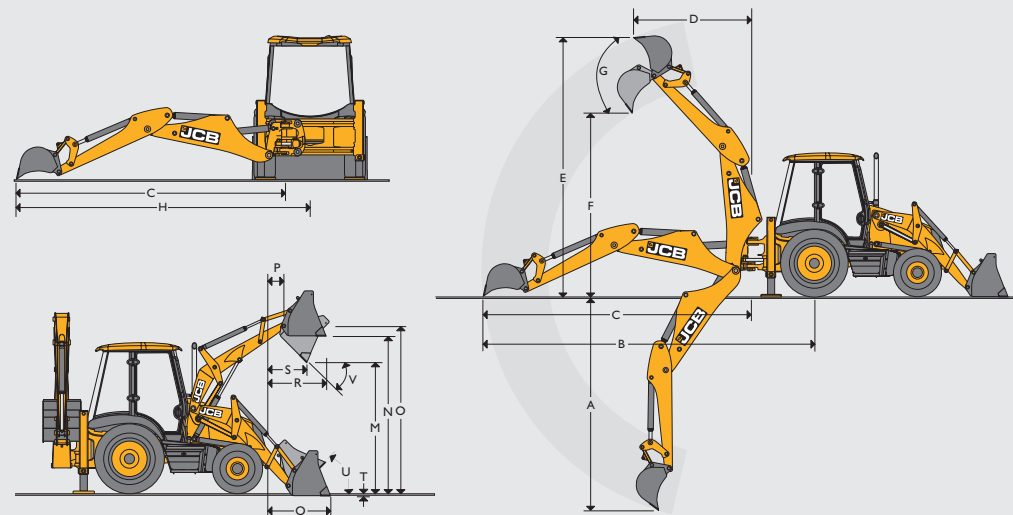

## Excavator performance

		Fixed dipper	Extending dipper
A	Max dig depth	m 4.24	5.46
B	Reach-ground level to rear wheel center	m 6.72	7.87
C	Reach-ground level to slew center	m 5.37	6.52
D	Reach at full height to slew center	m 2.74	3.66
E	Max. working height	m 5.53	6.35
F	Max. load over height	m 3.84	4.72
G	Bucket rotation – power/speed	degrees 185°	185°/201°
H	Side reach to centre line of machine	m 5.94	7.09
	Bucket breakout force	kgf 6324	6228
	Dipper breakout force	kgf 3217	3225

## Loader performance

		GP	6-in-1
M	Dump height	m 2.74	2.72
N	Load over height	m 3.23	3.20
O	Pin height	m 3.45	3.45
P	Pin forward reach	m 0.36	0.36
Q	Reach at ground	m 1.42	1.37
R	Max. reach at full height	m 1.20	1.15
S	Reach at full height – bucket dumped	m 0.83	0.78
T	Below ground level dig depth	m 0.07	0.10
U	Rollback at ground	degrees 45°	45°
V	Dump angle	degrees 43°	43°
	Shovel breakout force	kgf 6170	6531
	Loader arm breakout force	kgf 4942	4732
	Shovel capacity	m <sup>3</sup> 1.1	1.0
	Loader lift capacity	kg 3495	3205

## SERVICE CAPACITIES

Cooling system	ltr	18.5
Fuel tank	ltr	128
Engine oil with filter	ltr	15
Gearbox with filter	ltr	16
Rear axle	ltr	16
Front axle	ltr	16
Hydraulic system incl. tank	ltr	130
Hydraulic tank	ltr	85

## TRANSMISSION

JCB Synchro-shuttle transmission: It provides superb drive power in all conditions. It consists of a 4-speed, full synchromesh gearbox with integral torque convertor and electrically operated reversing power shuttle.

- Easy-to-use, column mounted electric reversing shuttle which can change machine direction while allowing operator to keep hands on the steering wheel leading to fast cycle times.
- The pedal layout and conventional 4-pattern gear lever with transmission disconnect switch adds to the overall ease of operation. On-the-move gear changes are possible.
- Torque convertor stall ratio is 2.52:1

Manufacturer	JCB
Type	Synchroshuttle
Gears forward/reverse	4 forward/4 reverse
Shuttle control – F/R	Power shuttle
<b>Travel speeds*</b>	<b>kph</b>
Gear 1	7.3
Gear 2	11.7
Gear 3	22
Gear 4	40

\*Speeds may vary dependant on tire selection.

## TURNING CIRCLE

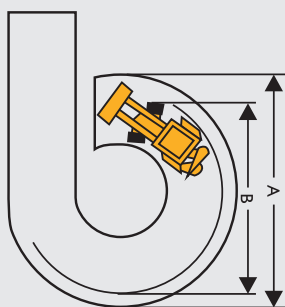

\* Standard bucket in travel position

## Inner wheels braked

A Outside loader bucket	9.50m
B Outside wheels	6.90m

## Inner wheels not braked

A Outside loader bucket	10.40m
B Outside wheels	8.10m

<b>STEERING</b>	Front wheel full power hydrostatic system utilizing the main hydraulic pump via a steering priority valve. In the event of engine failure, emergency steering is maintained (all models).
<b>BRAKES</b>	<b>Service:</b> Hydraulically actuated dual line, self adjusting, oil immersed, multi-disc type on the rear axle, well protected from dirt, water etc. requiring no maintenance. <b>Parking:</b> Hand operated, disc brake on rear axle input disc. <b>Brake pedal:</b> Two independently operable foot pedals enable machine to manoeuvre in tight spaces. Pedals are linked together for normal use.
<b>HYDRAULIC SYSTEM</b>	• Main relief valve: 251 bar • Unloader valve: 207 bar • Pump type: 2 section displacement gear • Pump capacity: 123 l/min - 143 l/min* • Filtration through suction strainer and return line JCB Filtermatic filter • During excavation the circuit automatically varies hydraulic power to match digging conditions for extra performance, control and power • Careful routing of hydraulic hoses and pipework guards against site damage and allows easy servicing.
<b>CAB</b>	• Floor mats • Fully adjustable seat and soft touch steering wheel • 'Walk through' two door access • Seat belt • Large convex rear view mirror • Interior light • Front screen wiper • Horn • Hazard warning system • Tool box • Instrumentation panel includes engine speed, engine hours, fuel level, water temperature gauge and 12v connection • Audible and visual fault warning system for alternator charge, coolant temperature, engine oil pressure, blocked air filter, transmission oil pressure and temperature, and hand brake on • ROPS/FOPS level 2 certified.
<b>AXLES</b>	<b>Rear:</b> Drive axle rigidly mounted, incorporates JCB Max-Trac torque proportioning differential, driven by short propshaft from gear box. <b>Front:</b> 4WD, Steer axle, centrally pivoted with oscillation angle of 16°.
<b>ELECTRICAL AND INSTRUMENTATION</b>	12 volt negative ground, utilising wiring and connectors meeting IP69 water ingress test standard. Central fuse panel. <b>Battery:</b> 110 A/hr <b>Alternator:</b> 95 amp standard. <b>Rear working lights:</b> 4 adjustable. <b>Front working lights:</b> 4 adjustable.
<b>TYRES</b>	<b>Standard:</b> Sitemaster 12.5-18/80 12ply (Front) Sitemaster 16.9-28 (Rear)
<b>WEIGHT</b>	<b>Operating:</b> 7800kg (17196lb)

\*Regional dependent.



### LOADER ATTACHMENTS – 6 in 1 Shovel Fork Dimensions

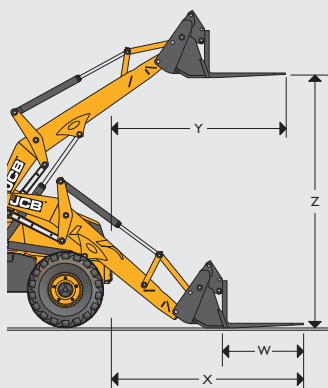

#### 6-in-1 bucket mounted forks

W	Forks – tine length	m	1.1
	Forks – tine width	m	0.08
X	Forks reach at ground level	m	2.66
Y	Forks reach at full height	m	2.25
Z	Forks lift height – max	m	2.92
	Fork spacing – min/max	mm	260 to 1725

### LOADER ATTACHMENTS – Direct Mount

HD GP shovel – 2337mm, 1m <sup>3</sup>	kg	770
6-in-1, with forks – 2337mm, 1m <sup>3</sup>	kg	880

### BACKHOE ATTACHMENTS – Patch Planer

Cutting width	mm	400
Cutting length	mm	1-115
Weight	kg	540
Hydraulic flow range	lpm	90-200
Hydraulic pressure range	psi (bar)	2030-3046 (140-210)

### BACKHOE ATTACHMENTS – Buckets

Bucket width	mm	305	455	610	610	760	910
Number of teeth		3	4	4	5	5	6
<b>Heavy-duty trenching buckets</b>			18	24	24	30	36
Capacity	cu m	0.08	0.14	0.20	0.20	0.26	0.32
Weight	kg	100	128	145	190	166	189
<b>Heavy-duty high capacity trenching buckets</b>			4	4	5	14.1 (5)	-(6)
Capacity	cu m	0.15	0.24	0.24	0.32	14.1	-
Weight	kg	195	231	233	267	303	-

See your JCB Dealer for availability of backhoe buckets and attachments.

All JCB buckets include heavy-duty features consisting of a 1"x18" cutting edge, back straps, box section cross member, and full length, chamfered side cutters.

### BACKHOE ATTACHMENTS – Hydraulic Breakers

Breaker model		HM380	HM386Q
Operating weight	kg	330	360
Impact energy	joules	981	600
Impact frequency	bpm	380-900	720-1380
Oil flow range	lpm	40-80	60-100
Operating pressure	psi (bar)	120-165 (1740-2393)	1450-2175 (100-150)
Tool diameter	mm	75	80

A wide variety of tools are available for JCB breakers. See your JCB Dealer for details.

### BACKHOE ATTACHMENTS – Compactor

Weight	kg	179
Width	mm	305
Length	mm	739
Optimum machine down force	kg	700
Centrifugal force	kN	16.3
Frequency	Hz	33
Oil flow	lpm	24

### BACKHOE ATTACHMENTS – Auger\*

		ED3500	ED6000
Width	mm	254	253
Length	mm	591	614
Power head and hanger weight	kg	105	110
Oil flow @ 60rpm	lpm	60	104
Oil flow min.	lpm	115	115
Oil flow max.	lpm	300	300

### BACKHOE ATTACHMENTS – Auger Flights\*

Weight	mm	150 - 460
Width	kg	19 - 91.2
No. of teeth		2-16
Length	mm	1000 - 1200

\*available from September 2014













**ONE COMPANY, OVER 300 MACHINES.**

Your nearest JCB dealer

**Backhoe Loader 3CX**

Gross power: 68.6kW (92hp) Maximum dig depth: 5.46m  
 Maximum loader bucket capacity: 1.1m<sup>3</sup>

JCB Sales Limited, Rocester, Staffordshire, United Kingdom ST14 5JP.  
 Tel: +44 (0)1889 590312 Email: salesinfo@jcb.com  
 Download the very latest information on this product range at: [www.jcb.com](http://www.jcb.com)

©2014 JCB Sales. All rights reserved. No part of this publication may be reproduced, stored in a retrieval system, or transmitted in any form or by any other means, electronic, mechanical, photocopying or otherwise, without prior permission from JCB Sales. All references in this publication to operating weights, sizes, capacities and other performance measurements are provided for guidance only and may vary dependant upon the exact specification of machine. They should not therefore be relied upon in relation to suitability for a particular application. Guidance and advice should always be sought from your JCB Dealer. JCB reserves the right to change specifications without notice. Illustrations and specifications shown may include optional equipment and accessories. All images are correct at time of print. The JCB logo is a registered trademark of J.C. Bamford Excavators Ltd.

9999/5854 en-MEA/SEA 08/116 Issue 2 (T2 SS)

