



LOADALL | 550-80/560-80

Gross power: 97kW (130hp) | Lift capacity: 4999kg – 6000kg | Maximum lift height: 8.1m



STATIC DIMENSIONS

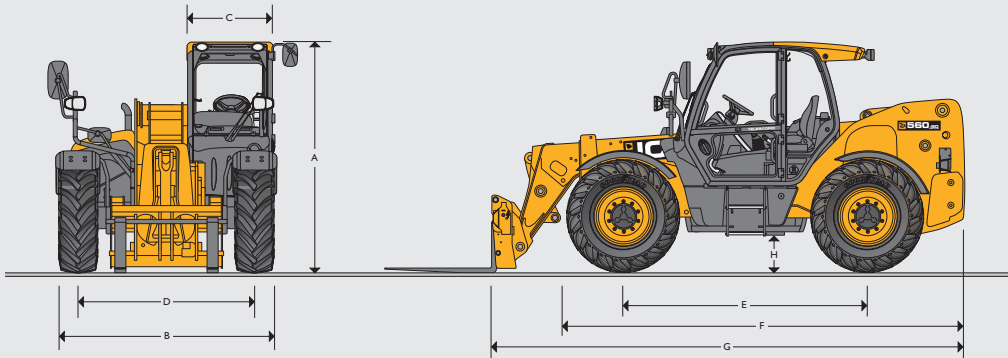

Model		550-80	560-80
A	Overall height*	m	2.59
B	Overall width (over tyres)*	m	2.54
C	Inside width of cab	m	0.94
D	Front track	m	1.98
E	Wheelbase	m	2.75
F	Overall length to front of tyres	m	4.42
G	Overall length to front of carriage	m	5.27
H	Ground clearance	m	0.4
	Outside turn radius (over tyres)	m	4.1
	Carriage rollback angle	degrees	47
	Carriage dump angle	degrees	33
	Weight**	kg	10500
	Tyres		440/80 R24 480/80 R26 500/70 R24
			480/80R26 500/70 R24

* Dependant upon tyre specified.

** Dependant upon tyre specified and machine specification.

ENGINE

Emissions level		Tier 3
Manufacturer		JCB
Displacement	litres	4.4
No. of cylinders		4
Bore size	mm	103
Stroke	mm	132
Aspiration		TCA
Power rating		
Power @ 2200rpm	kW (hp)	97 (130)
Torque rating		
Torque @ 1500rpm	Nm (lb/ft)	532 (392)

LIFT PERFORMANCE

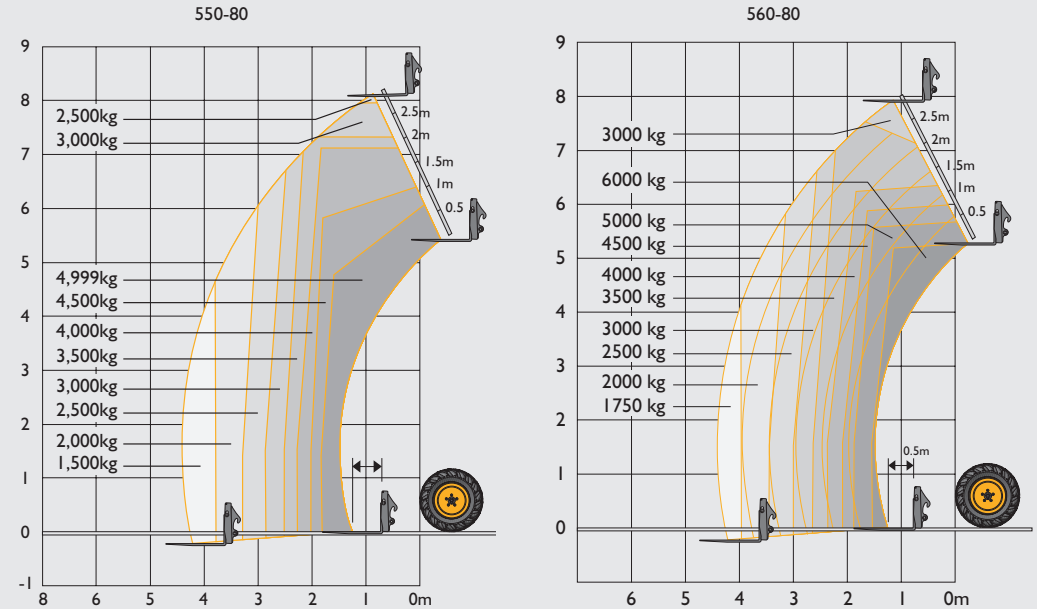

Model		550-80	560-80
Maximum lift capacity	kg	4999	6000
Lift capacity to full height	kg	2500	3000
Lift capacity at full reach	kg	1500	1750
Lift height	m	8.1	7.9
Reach at maximum lift height	m	0.97	0.92
Maximum forward reach	m	4.47	4.47
Reach with 1 tonne load	m	4.47	4.47
Placing height	m	7.45	7.25

Complies with stability test ISO 22915-14:2010.

TRANSMISSION

JCB Powershift Transmission incorporating torque converter and a bevel box in one resiliently mounted unit. Manual gear shift incorporated onto the single lever joystick. Travel speed 20kph (solid tyres), 36kph (24 inch tyres), 40kph (26 inch tyres). Permanent 4 wheel drive (optional 2/4wd disconnect). Front and rear drive axles: Epicyclic hub reduction drive/steer axles with torque proportioning differentials.

ELECTRICAL SYSTEM

System voltage	Volt	12
Alternator output	Amp hour	95
Battery capacity	Amp hour	120

Full road lighting capability. Reversing light. Directional indicators. Hazard warning. Reverse alarm.

HYDRAULICS

Operating system pressure	bar	260
Main hydraulics	l/min	140
Pump	l/min	Variable displacement
Loader controls		Cab mounted single lever joystick – Electric servo control of all lift end functions.

SERVICE CAPACITIES

Fuel tank	litres	146
Hydraulic tank	litres	113
Engine oil sump	litres	14
Engine coolant system	litres	23

BRAKES

Service brakes: Hydraulically activated power brakes, self-adjusting, oil-immersed in-board multi-disc type on front and rear axles.

Parking brake: Hand operated oil immersed disc type.

Switchable transmission disconnect on brake application.

BOOM AND CARRIAGE

Boom is manufactured from high tensile steel. Low maintenance, hard wearing pads. JCB Q-fit self-levelling carriage with lever operated pin locking accepts pallet forks and a wide range of attachments. One boom end auxiliary hydraulic service fitted as standard.

SAFETY CHECK VALVES

Fitted to carriage tilt, telescopic and boom lift rams.

VIBRATION

Whole body vibrate emission	0.42m ²	In accordance with ISO 2631-1:1997
-----------------------------	--------------------	------------------------------------

STEERING

Hydrostatic power steering with power track rods on both axles. Three steer mode options: front wheel steer; all wheel steer; crab steer: operated from in the cab by a selection switch, with automatic alignment.

CAB

Quiet, safe and comfortable cab conforms to ROPS ISO 3471 and FOPS ISO 3449. Tinted glass all round with laminated front and roof screen. Roof bars, front, rear and roof screen wash/wipe and heater/screen demister. Opening rear window. Audio-visual warning system for coolant temperature, water in fuel, engine oil pressure, air cleaner, battery charge, transmission oil temperature and pressure. Brake charge, hourmeter and road speed indicator. Engine temperature, fuel gauge and clock. Adjustable stalk bar and forward reverse shuttle. Floor mounted throttle pedal. Adjustable deluxe suspension seat with adjacent park brake. Automatic eye level audio-visual load moment indicator warning system receiving a signal from a load sensor on the rear axle. This system continuously monitors the machine's forward stability and leaves the operator in control at all times.

Hydraulic controls: Cab mounted single lever servo joystick, incorporating forward/neutral/reverse, transmission disconnect, with progressive extend/retract and auxiliary incorporating constant flow facility.

OPTIONS AND ACCESSORIES

Boom worklights, road lights, rotating beacon (magnetic or adjustable), fire extinguisher, heated glass, front windscreen guard, roof guard, transmission protection plate, fuel tank protection kit, electrical 2/4wd select, wheel nut indicators, 2nd boom auxiliary, variable speed reversing fan, air conditioning, engine block heater, exhaust heat shield, biodegradable oil.
Mechanical suspension seat and air suspension seat options.

Attachments: Contact your local dealer for details of the comprehensive range. Carriage options available- contact your local dealer.



ONE COMPANY, OVER 300 MACHINES.

Your nearest JCB dealer

Loadall 550-80/560-80

Gross power: 97kW (130hp)

Lift capacity: 4999kg – 6000kg Maximum lift height: 8.1m

JCB Sales Limited, Rokester, Staffordshire, United Kingdom ST14 5JP.

Tel: +44 (0)1889 590312 Email: salesinfo@jcb.com

Download the very latest information on this product range at: www.jcb.com

©2009 JCB Sales. All rights reserved. No part of this publication may be reproduced, stored in a retrieval system, or transmitted in any form or by any other means, electronic, mechanical, photocopying or otherwise, without prior permission from JCB Sales. All references in this publication to operating weights, sizes, capacities and other performance measurements are provided for guidance only and may vary dependant upon the exact specification of machine. They should not therefore be relied upon in relation to suitability for a particular application. Guidance and advice should always be sought from your JCB Dealer. JCB reserves the right to change specifications without notice. Illustrations and specifications shown may include optional equipment and accessories. All images are correct at time of print. The JCB logo is a registered trademark of J C Bamford Excavators Ltd.



9999/TBC en-GB 07/17 Issue 1 (T3)

