



## WHEEL LOADER | 426/436

426 – Gross rated power: 112kW (150hp) Operating weight: 12,740kg Full turn tipping load: 8,271kg Standard shovel capacity: 2.1m<sup>3</sup>

436 – Gross rated power: 129kW (173hp) Operating weight: 14,564kg Full turn tipping load: 9,436kg Standard shovel capacity: 2.7m<sup>3</sup>



## A QUALITY PROCESS.

PURPOSE-DESIGNED AND BUILT TO COPE WITH THE MOST DEMANDING SITES ON EARTH, THE 426 AND 436 OFFER PREMIUM QUALITY AND RELIABILITY. THE PROCESSES WE'VE USED IN ITS DESIGN AND MANUFACTURE WILL ENSURE THAT WORK GOES ON HOUR AFTER HOUR, DAY AFTER DAY.



### Designed to work hard.

**1** We use state-of-the-art manufacturing processes like robot machining, precision paint technology and innovative assembly techniques to achieve the very highest levels of build quality.

**2** Finite element analysis and rig testing ensure the superior structural strength and durability; to guarantee that the 426 or 436 will perform anywhere for you, we carry out extreme hot and cold climate testing.

**3** Recessed rear lights are protected within the solid counterweight; the counterweight and cast quarter pillars also protect the cooling pack and the back end of the machine from damage





## Built to last.

- 4** JCB Smoothride load suspension limits shock loadings and therefore reduces material spillage and structural stress, as well as increasing operator comfort.
- 5** Precision machining provides high tolerances and accurate location of the 426 and 436's pins and bushes.
- 6** Hoses are neatly routed and clamped through the articulation joint, well away from any pinch points.
- 7** The articulation joint has a heavy-duty box section (much stronger than a single plate with a boss), a heavy-duty centre pin and oversized bush as well as twin taper roller bearings on the bottom box joints. This setup can tolerate both vertical and horizontal loadings for durability and rigidity. Steering rams are positioned high up and protected from damage.



4



5



7

6

# PRODUCTIVE PERFORMANCE.

NO MATTER WHERE IN THE WORLD YOU'RE OPERATING, THE NEW JCB 426 AND 436 WILL PERFORM GREAT FEATS OF PRODUCTIVITY. ITS ENGINE OFFERS HIGH POWER AND TORQUE, WHILE ITS HYDRAULICS AND LOADER END ARE SET UP TO KEEP CYCLE TIMES SHORT AND WORKING SHIFTS LONG.

## Powering it all.

**1** A perfectly matched, balanced powertrain provides the power to move even the most demanding material from A to B.

**2** The 426 and 436 boast an air-to-air intercooled low-emission engine with electronically controlled fuel-injection system. This delivers high torque at a low engine RPM, enabling the operator to fill the bucket faster.

**3** The 426 and 436 feature a fully automatic transmission. With this system the gear is automatically and immediately selected ensuring the absolute maximum productivity and fuel efficiency, and prolonging the life of the machine.

**4** The 436 is fitted with standard torque proportioning axles that keep the machine moving even in difficult conditions. If one wheel is slipping, power is automatically transferred to the wheel with traction. Torque is also increased at the hubs, which reduces stress on other components. There's also the option to have even more advanced limited slip differentials.

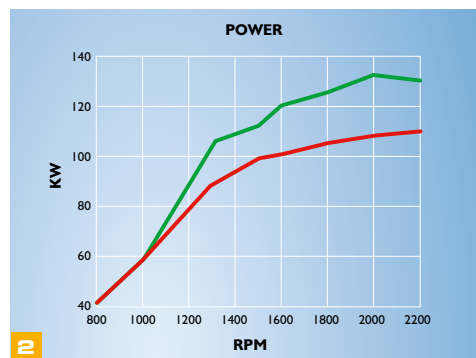

■ 426 ■ 436

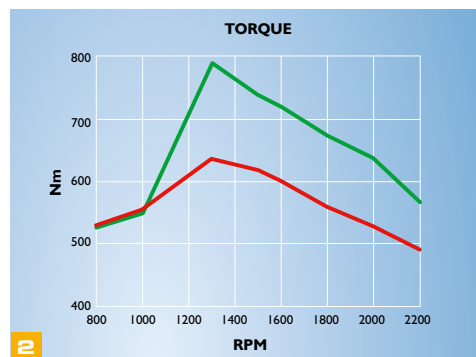



### Loading productivity.

5 The oil-immersed braking system not only ensures effective braking but also a long service life. Wheel speed braking means the brakes on the 436 rotate at the same speed as the wheels for heat and drag reduction, as well as improved fuel economy.

6 The 436 delivers efficient hydraulic oil flow on demand thanks to a load-sensing circuit. This minimises fuel consumption, directs power where it is needed most and allows for accurate and efficient load placements. When it comes to driving, the steering requires minimum effort, even at full articulation.

7 You can choose your ideal loader arm on a 426 or 436, with Z-bar linkage (ZX) for high breakout applications or high torque (HT) for parallel lift and multi-attachment use.

Choose a HT high lift on the 426 or 436, or a super high lift HT on the 436 and you can use the machine for higher loading height applications (hopper and lorry loading).



5



Z bar (ZX)

HT Standard Lift

HT High Lift

HT Super High Lift

4

## COMFORTABLY SUPERIOR.

KEEPING OPERATORS FRESH AND ALERT ALL DAY LONG RESULTS IN INCREASED SAFETY AND PRODUCTIVITY. WITH THAT IN MIND, THE NEW 426/436'S 3M<sup>3</sup> CAB IS ROOMY, EASY TO ACCESS AND QUIET. IT ALSO HAS EXCELLENT VISIBILITY AND AN INTUITIVE, ERGONOMIC CONTROL LAYOUT.



1

### A comfortable operator.

1 At 3m<sup>3</sup>, the 426/436 has one seriously large operator environment, with every detail ergonomically designed for comfort and ease of use. There's also plenty of space for storage, including a massive open-floor space.

2 The 360 degree tinted glass cab allows the operator to not only spot almost all potential hazards, but also to view the load throughout its full lift range. The cab features narrow uprights

between the glass panels, an extra large wiper and a choice of front and rear blinds to keep the sun off.

3 The standard high-backed suspension seat is fully adjustable and provides excellent support and comfort. The result is reduced operator fatigue for added productivity.

4 The excellent heating and ventilation systems ensure ideal working temperatures. An optional air-conditioning system and heated, air-suspended seat is also available.



2

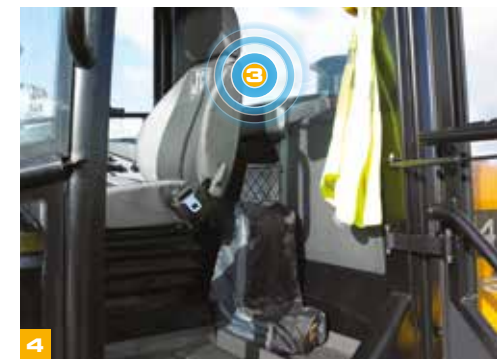

4





### A good place to work.

- 5 When it's cold outside, the heated mirrors prevent icing. Plus, there are two interior mirrors that provide superb views of hard-to-see areas.
- 6 All the 426 and 436 controls are conveniently placed and incredibly easy to use. There's a choice of multi-lever or single-lever controllers to suit your operator's preference. Both controllers feature

gear-change and disconnect switches, and the latter speeds things up by transferring engine power to the hydraulics.

- 7 A tilting and telescopic steering column provides easy adjustment for maximum comfort.



## LOW MAINTENANCE, LONG INTERVALS.

JCB RECOGNISES THAT WHEEL LOADERS NEED TO SPEND THE MAXIMUM AMOUNT OF TIME HARD AT WORK FOR YOU. WE'VE THEREFORE DESIGNED THE 426 AND 436 TO DO JUST THAT, WITH LONG SERVICE INTERVALS AND QUALITY COMPONENTS.

### Access all areas.

- 1 You can gain access to the 426 and 436's engine bay and cooling pack areas easily with wide-opening gullwing doors.
- 2 Daily check and grease points are accessible from ground level, making life easier and safer for your operators.
- 3 The cooling pack is a single faced unit, allowing excellent access for cleaning.

The standard widecore cooling pack and optional reversing fan will ensure cooling efficiency in environments with large amounts of airborne debris.

- 4 The 426 and 436's electric monitoring system relays key information and real time alerts, safeguarding both machine and operator.

- 5 By using top components in the 426 and 436 (Cummins engine, ZF transmission and axles, Rexroth pumps and Parker valve block), we've built in long service life as standard.



1



2



4



5



## DRIVE SAFELY.

IT'S ESSENTIAL TO KEEP WORKSITES SAFE AT ALL TIMES SO THE NEW JCB 426 AND 436 OFFER GREAT VISIBILITY, NON-SLIP SURFACES, AIR FILTRATION AND MANY MORE

### Safety first.

- 1 Access steps are inclined and equally spaced, complemented by well positioned grab handles for three points of contact at all times.
- 2 The cab is isolator-mounted, compliant with ROPS/FOPS standards, and positively pressurised against dust. You can choose from either fresh air or carbon recirculation filters as well.
- 3 Interior mirrors, heated exterior mirrors and bonnet mirrors combine to provide superb all-round visibility.
- 4 Our rear-view camera option displays an unobstructed rear view on an in-cab colour monitor.
- 5 Increase visibility further by opting for our LED worklight option.



2



1



3

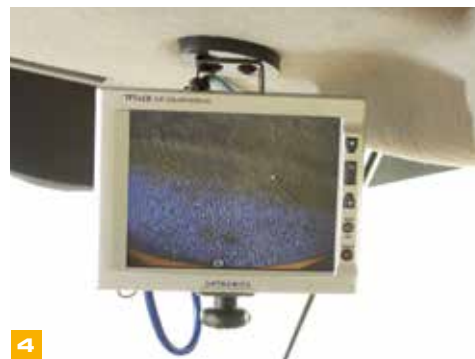

4



4



5



## LIVELINK TELEMATICS.

LiveLink telematics helps you monitor and manage your machine fleet remotely anywhere in the world by radically improving the efficiency, productivity, safety and security of all your JCB and non JCB machine fleet.

**MACHINE EFFICIENCY:** Keep track of your machine's daily activity with regular performance reports which provide information about idle time, location, machine health, error codes for diagnostics, engine utilisation by power band, safety alerts, and fuel consumption. JCB LiveLink ensures machines are kept running for maximum uptime and return on investment.

**MACHINE RELIABILITY:** Accurate hours and service alerts improve maintenance planning to optimise machine productivity.

**MACHINE SECURITY:** LiveLink's real time geo-fencing alerts tell you when machines move out of predetermined zones. Curfew alerts inform you of unauthorised usage.



Track the location of any asset via Bluetooth connection.



An after market telematics solution which can be retrofitted to any machine.



## COMPLETE CONTROL FOR YOUR FLEET.

LiveLink Fleet enables you to track every aspect of your equipment to maximise efficiency and machine uptime.

**GUESS LESS, KNOW MORE:** Equipment issues and service reminders are logged as soon as they occur, helping you to react quickly.

**YOUR EYES ON THE GROUND:** Integrate LiveLink Fleet with the JCB Operator mobile app and data from your operators' daily equipment checks feed instantly into your dashboard.

**TOTAL PEACE OF MIND:** Operator safety alerts help to ensure machines are being used efficiently and safely.

**SMARTER TOOLS. SMARTER DECISIONS:** From hours worked to fuel wastage, access custom analytics on your fleet to make smarter decisions, quicker.

**EFFORTLESS MEETS PAPERLESS:** Access certificates, warranty information, quick start machine guides and manuals.

## The JCB Operator app

### THEY SPOT IT, YOU KNOW IT.

The JCB Operator app gives you faster, clearer and more accurate information about your fleet, direct from the people using your equipment each day.

**STAY IN TOUCH:** Get regular checks on your machine with visibility in the LiveLink Fleet portal.

**TAILOR YOUR CHECKS:** Customise your checklists to suit any application, customer or site.

**UPLOAD TO KEEP UPDATED:** Upload useful information with photos and comments.

**FULLY COMPATIBLE:** The JCB Operator app works with non telemetry related machines and assets.

**ACCESS ALL INFORMATION:** Get access to documentation such as quick start guides.

\*The individual features of LiveLink Telematics, LiveLink Fleet and Operator App vary per region, engine and machine type.



## FULLY SUPPORTED.

JCB'S WORLDWIDE CUSTOMER SUPPORT IS FIRST CLASS. WHATEVER YOU NEED AND WHEREVER YOU ARE, WE'LL BE AVAILABLE QUICKLY AND EFFICIENTLY TO HELP MAKE SURE YOUR MACHINERY IS PERFORMING TO ITS FULL POTENTIAL.



1

1 Our Technical Support Service provides instant access to factory expertise, day or night, while our Finance and Insurance teams are always on hand to provide fast, flexible, competitive quotes.

2 The global network of JCB Parts Centres is another model of efficiency; with 18 regional bases, we can deliver around 95% of all parts anywhere in the world within 24 hours. Our genuine JCB parts are designed to work in perfect harmony with your machine for optimum performance and productivity.



2

3 JCB offers comprehensive extended warranties as well as service-only or repair and maintenance contracts. Irrespective of what you opt for, our Maintenance teams around the world charge competitive labour rates, and offer non-obligation quotations as well as fast, efficient insurance repair work.



3

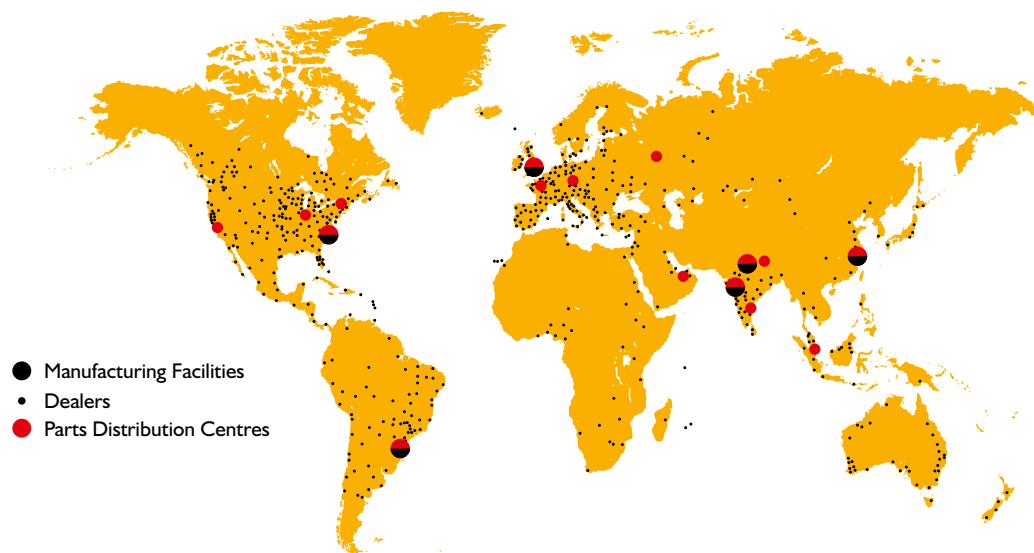

Note: JCB LIVELINK and JCB extended warranty packages may not be available in your region, so please check with your local dealer.

## STATIC DIMENSIONS – HT (HIGH-TORQUE)

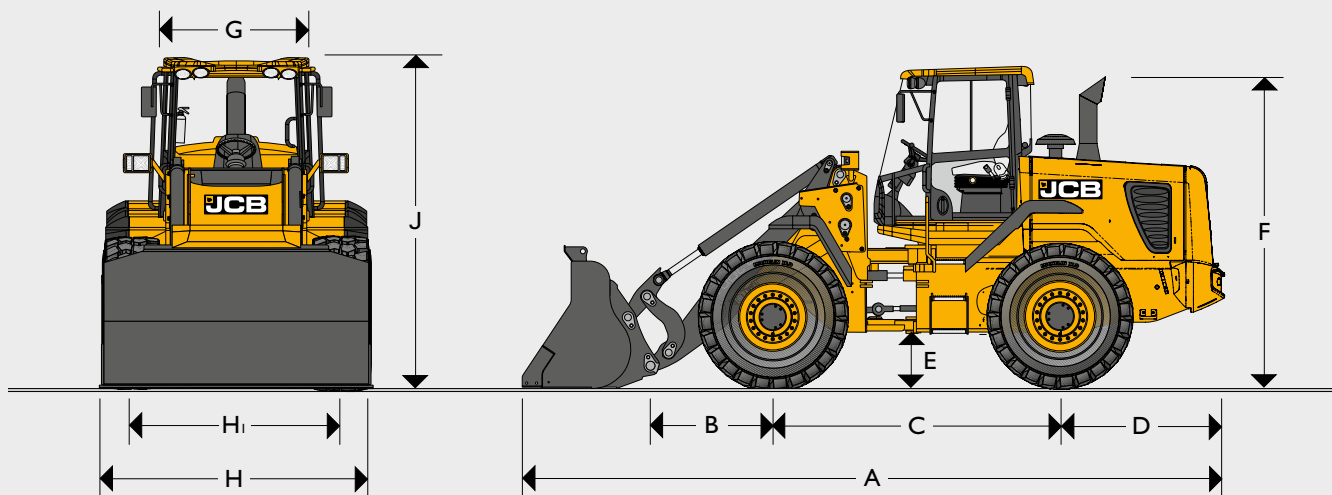

			426 HT	426 HT HL	426 ZX	436 HT	436 HT HL	436 HT SHL	436 ZX
A	Overall length	mm	6831	7244	6831	6926	7282	7726	7169
B	Axle to pivot pin	mm	1096	1509	1096	1143	1499	2366	1143
C	Wheel base	mm	3000	3000	3000	3000	3000	3000	3000
D	Axle to counterweight face	mm	1816	1816	1816	1816	1816	1816	1816
E	Minimum ground clearance	mm	442	442	442	459	459	459	459
F	Height over exhaust	mm	3236	3192	3192	3192	3192	3192	3192
G	Width over cab	mm	1400	1400	1400	1400	1400	1400	1400
H	Width over tyres	mm	2482	2482	2482	2597	2597	2597	2597
HI	Wheel track	mm	1955	2070	1955	2070	2070	2070	2070
J	Height over cab	mm	3335	3335	3335	3335	3335	3335	3335
	Pin height (maximum)	mm	3906	4336	3906	3996	4650	5213	3996
	Overall operating height	mm	5095	5525	5095	5305	5959	6522	5305
	Front axle weight	kg	5574	5869	5830	6013	7133	7968	6456
	Rear axle weight	kg	7126	7101	7020	8490	7860	7577	8466
	Total weight	kg	12700	12970	12850	14503	14993	15545	14922
	Inside radius	mm	2920	2825	2920	2825	2825	2825	2825
	Maximum radius over shovel	mm	5790	5985	5790	5860	6000	6196	5900
	Articulation angle	degrees	± 40°	± 40°	± 40°	± 40°	± 40°	± 40°	± 40°

426 data based on machine equipped with pin mounted 1.9m<sup>3</sup> bucket with toe plates and Michelin 20.5 R25 XHA2 (L3) radial tyres.

436 data based on machine equipped with pin mounted 2.4m<sup>3</sup> bucket with toe plates and Michelin 20.5 R25 XHA2 (L3) radial tyres.



**CHANGES TO OPERATING PERFORMANCE AND DIMENSIONS**

426 HT					Standard arms		HI LIFT arms		Dimensions	
Tyre size	Manufacturer	Type	Rating	Op weight kg	STL kg	FTTL kg	STL kg	FTTL kg	Vertical mm	Width mm
20.5 - 25 (crossply)	Firestone	SGG	L2	-348	-245	-215	-204	-179	-9	+5
20.5 - 25 (crossply)	Goodyear	SGL D/L	L2	-216	-152	-134	-126	-111	-9	+5
20.5 R 25 (radial)	Goodyear	RL - 2 +	L2	+76	+54	+47	+45	+39	-9	+5
20.5 R 25 (radial)	Bridgestone	VUT	L2	-160	-113	-99	-94	-82	0	0
20.5 R 25 (radial)	Michelin	XTLA	L2	-160	-113	-99	-94	-82	-9	+5
20.5 R 25 (radial)	Bridgestone	VMT	L3	0	0	0	0	0	0	0
550/65 R 25 (radial)	Michelin	XLD	L3	-120	-85	-75	-71	-62	0	0
20.5 R 25 (radial)	Michelin	XRDIA	L4	+332	+257	+206	+214	+171	+29	+8
20.5 R 25 (radial)	Michelin	XMINED2	L5	+680	+480	+421	+399	+350	+29	-3
20.5 R 25 (radial)	Goodyear	RL-5K	L5	+600	+423	+372	+352	+310	+29	-3
620/75 R25 (radial)	Michelin	MEGA XBIB		-107	-75	-67	-62	-56	+62	+258
20.5R25 (radial)	JCB	Earthmover	L3	128	90	78	77	47	41	12
20.5-25 (crossply)	JCB	Sitemaster	L3	100	70	61	60	37	21	-7
Optional additional bolt-on counterweight				+380	+707	+598	+604	+513	0	0

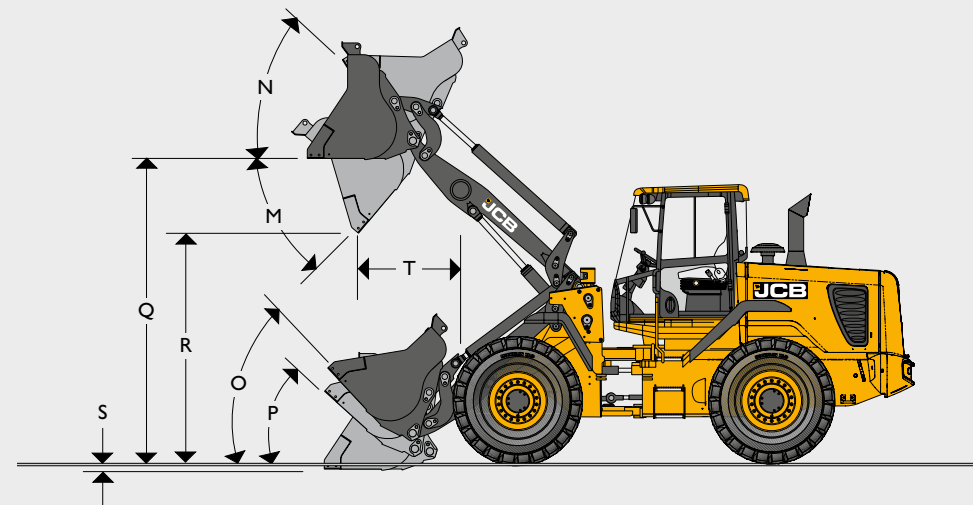

**LOADER DIMENSIONS – 426 HT**

Assumes the machine is fitted with 1.9m³ shovel with toeplates and Michelin 20.5R25 XHA (L3) tyres.

Model	426 HT – STANDARD HEIGHT ARM												426 HT – HI LIFT ARM												
	Direct						Quickhitch						Direct						Quickhitch						
	General purpose												General purpose												
Bucket equipment	Tipped teeth		Reversible toeplate				Tipped teeth		Reversible toeplate				Tipped teeth		Reversible toeplate				Tipped teeth		Reversible toeplate				
Bucket capacity (SAE heaped)	m³	1.8	2.0	1.9	2.1	2.4	2.7	1.8	2.0	1.9	2.1	2.4	2.7	1.8	2.0	1.9	2.1	2.4	2.7	1.8	2.0	1.9	2.1	2.4	2.7
Bucket capacity (struck)	m³	1.556	1.765	1.616	1.830	2.057	2.346	1.554	1.749	1.594	1.787	2.057	2.346	1.556	1.765	1.616	1.830	2.057	2.346	1.554	1.749	1.594	1.787	2.057	2.346
Bucket width	mm	2550	2550	2550	2550	2700	2700	2550	2550	2550	2550	2700	2700	2550	2550	2550	2550	2700	2700	2550	2550	2550	2550	2700	2700
Bucket weight	kg	810	850	810	850	1136	1211	800	850	800	850	1136	1211	810	850	810	850	1136	1211	800	850	800	850	1136	1211
Maximum material density	kg/m³	2332	2068	2209	1969	1655	1439	2125	1884	2013	1794	1508	1311	1947	1726	1844	1644	1381	1201	1774	1573	1681	1498	1260	1095
Tipping load straight	kg	9819	9797	9819	9797	9334	9147	8983	8859	8983	8859	8554	8384	8199	8180	8199	8180	7794	7638	7501	7397	7501	7397	7142	7000
Tipping load full turn	kg	8396	8271	8396	8271	7944	7774	7650	7537	7650	7537	7243	7085	7010	6906	7010	6906	6633	6491	6388	6293	6388	6293	6048	5916
Payload	kg	4198	4136	4198	4136	3972	3887	3825	3768	3825	3768	3621	3542	3505	3453	3505	3453	3316	3245	3194	3146	3194	3145	3024	2958
Maximum break out force	kN	138	128	138	128	123	115	121	113	121	113	106	99	138	128	138	128	123	115	121	113	121	113	106	99
M Dump angle maximum	degrees	49°	49°	49°	49°	49°	49°	49°	49°	49°	49°	49°	49°	45°	45°	45°	45°	45°	45°	45°	45°	45°	45°	45°	45°
N Roll back angle full height	degrees	58°	58°	58°	58°	58°	58°	58°	58°	58°	58°	58°	58°	58°	58°	58°	58°	58°	58°	58°	58°	58°	58°	58°	58°
O Roll back at carry	degrees	48°	48°	48°	48°	48°	48°	48°	48°	48°	48°	48°	48°	50°	50°	50°	50°	50°	50°	50°	50°	50°	50°	50°	50°
P Roll back at ground level	degrees	43°	43°	43°	43°	43°	43°	43°	43°	43°	43°	43°	43°	48°	48°	48°	48°	48°	48°	48°	48°	48°	48°	48°	48°
Q Load over height	mm	3627	3627	3612	3612	3610	3610	3627	3627	3612	3612	3610	3610	4057	4057	4042	4042	4040	4040	4057	4057	4042	4042	4040	4040
R Dump height (45° dump)	mm	2817	2767	2944	2896	2860	2796	2697	2647	2848	2775	2739	2676	3247	3197	3374	3326	3290	3226	3212	3127	3278	3205	3169	3106
S Dig depth	mm	50	50	47	47	47	47	50	50	47	47	47	47	113	113	110	110	110	110	128	113	110	110	110	110
T Reach at dump height	mm	1071	1121	946	99	1028	1092	1191	1240	1052	1118	1149	1213	1233	1983	1108	1158	1190	1254	1244	1253	1214	1280	1311	1375
Pin height	mm	3876	3876	3876	3876	3876	3876	3876	3876	3876	3876	3876	3876	4306	4306	4306	4306	4306	4306	4306	4306	4306	4306	4306	4306
Reach maximum (45° dump) – horizontal arm	mm	1818	1868	1693	1743	1775	1839	1938	1987	1800	1865	1896	1960	2166	2216	2041	2091	2123	2187	2177	2286	2148	2213	2244	2308
Operating weight (includes 80kg operator and full fuel tank)	kg	12700	12740	12700	12740	13025	13100	12980	13030	12980	13030	13316	13390	12970	13010	12970	13010	13925	13370	13250	13300	13250	13300	13586	13660

CHANGES TO OPERATING PERFORMANCE AND DIMENSIONS

426 ZX				Standard arms			Dimensions	
Tyre size	Manufacturer	Type	Rating	Op weight kg	STL kg	FTTL kg	Vertical mm	Width mm
20.5 - 25 (crossply)	Firestone	SGG	L2	-348	-245	-215	-9	+5
20.5 - 25 (crossply)	Goodyear	SGL	L2	-54	-38	-33	-9	+5
20.5 R 25 (radial)	Goodyear	RL - 2+	L2	+76	+54	+47	-9	+5
20.5 R 25 (radial)	Bridgestone	VUT	L2	-160	-113	-99	0	0
20.5 R 25 (radial)	Michelin	XTLA	L2	-160	-113	-99	-9	+5
20.5 R 25 (radial)	Bridgestone	VMT	L3	0	0	0	0	0
550/65 R 25 (radial)	Michelin	XLD	L3	-120	-85	-74	0	0
20.5 R 25 (radial)	Michelin	XRD1A	L4	+456	+332	+282	+29	+8
20.5 R 25 (radial)	Michelin	XMINED2	L5	+680	+480	+421	+29	-3
20.5 R 25 (radial)	Goodyear	RL-5K	L5	+600	+423	+372	+29	-3
20.5R25 (radial)	JCB	Earthmover	L3	128	86	74	41	12
20.5-25 (crossply)	JCB	Sitemaster	L3	100	67	58	21	-7
Optional additional bolt-on counterweight				+380	+707	+598	0	0

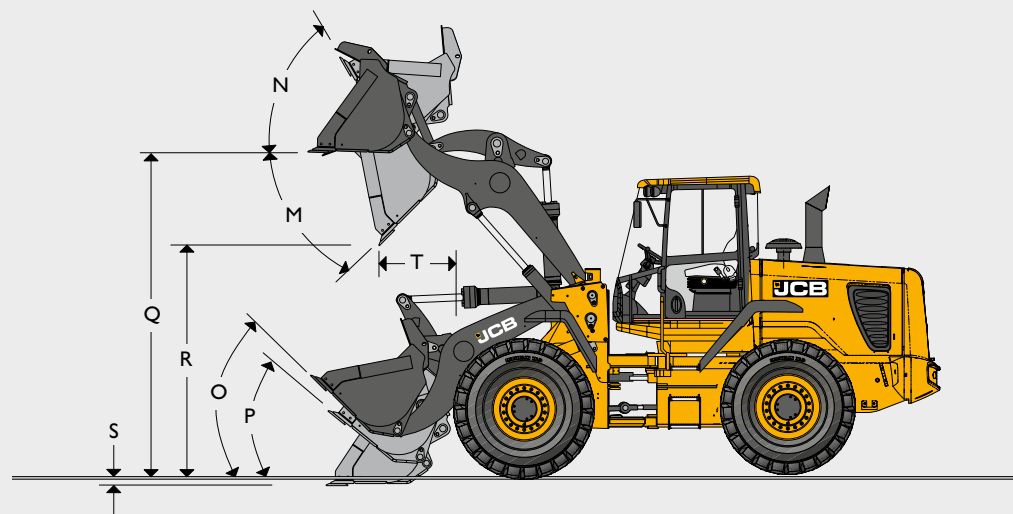

LOADER DIMENSIONS – 426 ZX

Assumes the machine is fitted with 1.9m³ shovel with toeplates and Michelin 20.5R25 XHA (L3) tyres.

Model	426 ZX															
	Direct						Quickhitch									
Bucket mounting	General purpose						General purpose				General purpose					
Bucket type	General purpose			Penetration			General purpose				General purpose					
Bucket equipment	Tipped teeth						Reversible toeplate				Tipped teeth			Reversible toeplate		
Bucket capacity (SAE heaped)	m³	1.8	2	2.3	2	1.9	2.1	2.4	2.7	1.8	2	2.3	1.9	2.1	2.4	2.7
Bucket capacity (struck)	m³	1.55	1.72	1.984	1.72	1.61	1.79	2.06	2.35	1.55	1.75	1.98	1.59	1.79	2.06	2.35
Bucket width	mm	2550	2550	2740	2550	2550	2550	2740	2740	2550	2550	2740	2550	2550	2740	2740
Bucket weight	kg	925	1040	1250	1140	925	1040	1262	1329	800	850	1124	800	850	1136	1211
Maximum material density	kg/m³	2298	2053	1761	2040	2203	1970	1677	1479	2152	1915	1559	2172	1943	1653	1447
Tipping load straight	kg	9687	9627	9516	9574	9795	9687	9465	9398	9067	8969	8432	9067	8969	8747	8680
Tipping load full turn	kg	8273	8212	8101	8159	8370	8273	8051	7984	7748	7659	7171	7748	7659	7437	7370
Payload	kg	4137	4106	4051	4080	4185	4137	4026	3992	3874	3830	3586	3874	3830	3719	3685
Maximum break out force	kN	145	135	129	135	145	135	129	120	126	118	113	126	118	113	106
M Dump angle maximum	degrees	45	45	45	45	45	45	45	45	45	45	45	45	45	45	45
N Roll back angle full height	degrees	52	52	52	52	52	52	52	52	52	52	52	52	52	52	52
O Roll back at carry	degrees	44	44	44	44	44	44	44	44	44	44	44	44	44	44	44
P Roll back at ground level	degrees	35	35	35	35	35	35	35	35	35	35	35	35	35	35	35
Q Load over height	mm	3645	3645	3638	3640	3640	3640	3638	3638	3645	3645	3638	3640	3640	3638	3638
R Dump height (45° dump)	mm	2850	2800	2889	2800	2973	2925	2889	2825	2726	2694	2768	2852	2804	2768	2704
S Dig depth	mm	15	15	15	15	30	30	32	32	33	33	32	30	30	32	32
T Reach at dump height	mm	1081	1131	1019	1131	936	986	1019	1083	1182	1232	1140	1057	1107	1140	1204
Pin height	mm	3904	3904	3904	3904	3904	3904	3904	3904	3904	3904	3904	3904	3904	3904	3904
Reach maximum (45° dump) – horizontal arm	mm	1828	1878	1776	1878	1683	1733	1766	1830	1929	1979	1907	1804	1854	1907	1951
Operating weight (includes 80kg operator and full fuel tank)	kg	12890	13005	13215	13105	12850	12890	13112	13179	13005	13045	13319	13005	13045	13331	13406



**CHANGES TO OPERATING PERFORMANCE AND DIMENSIONS**

436 HT				Standard arms		HI LIFT Arms		SHL Arms		Dimensions		
Tyre size	Manufacturer	Type	Rating	Op weight kg	STL kg	FTTL kg	STL kg	FTTL kg	STL kg	FTTL kg	Vertical mm	Width mm
20.5 - 25 (crossply)	Firestone	-	L2	-348	-208	-201	-168	-164	-135	-130	-9	+5
20.5 - 25 (crossply)	Goodyear	SGL	L2	-54	-32	-31	-25	-24	-21	-20	-9	+5
20.5 R25 (radial)	Goodyear	RL - 2 +	L2	+76	+45	+44	+36	+35	-73	-64	-9	+5
20.5 R25 (radial)	Bridgestone	VUT	L2	-160	-96	-93	-78	-76	+29	+28	0	0
20.5 R25 (radial)	Michelin	XTLA	L2	-160	-96	-93	-78	-76	-73	-64	-9	+5
20.5 R25 (radial)	Bridgestone	VMT	L3	0	0	0	0	0	0	0	0	0
550/65 R25 (radial)	Michelin	XLD	L3	-120	-71	-69	-55	-55	-46	-45	0	0
20.5 R25 (radial)	Michelin	XRD1A	L4	+456	+272	+264	+219	+215	-177	-171	+29	+8
20.5 R25 (radial)	Michelin	XMINED2	L5	+680	+407	+393	+321	+321	+264	+255	+29	-3
20.5 R25 (radial)	Goodyear	RL-5K	L5	+600	+358	+347	+289	+283	+232	+225	+29	-3
20.5R25 (radial)	JCB	Earthmover	L3	128	86	74	70	41	40	28	41	12
20.5-25 (crossply)	JCB	Sitemaster	L3	100	67	58	55	32	31	22	21	-7
Optional heavy counterweight				+380	+683	+570	+550	+466	+421	+353	0	0

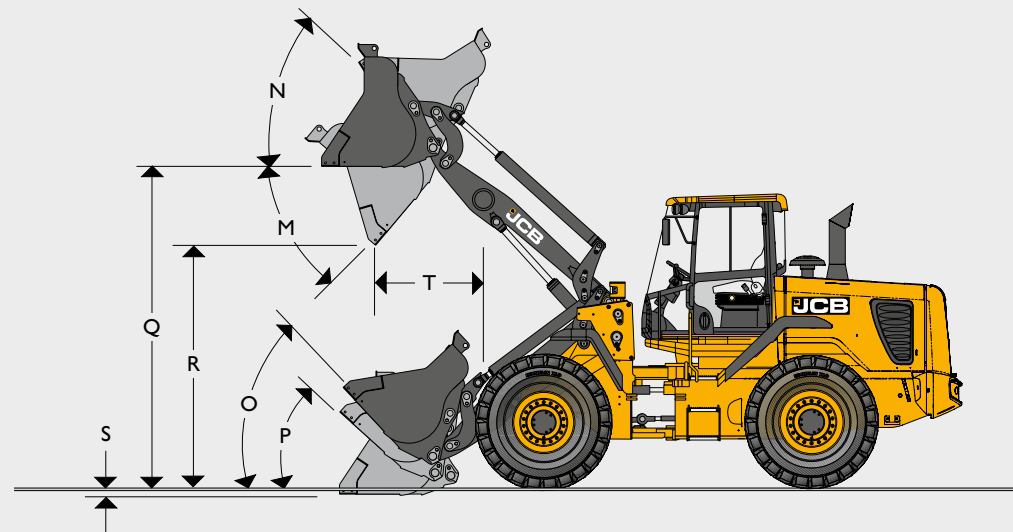

**LOADER DIMENSIONS – 436 HT**

Assumes the machine is fitted with Michelin 20.5R25 XHA (L3) tyres.

Model	436 HT – STANDARD HEIGHT ARM								436 HT – HI LIFT ARM								436 HT – SUPER HI LIFT ARM								
	Direct				Quickhitch				Direct				Quickhitch				Direct				Quickhitch				
	General purpose								General purpose								General purpose								
Bucket mounting																									
Bucket type																									
Bucket equipment																									
Bucket capacity (SAE heaped)	m³	2.3	2.6	2.4	2.7	2.3	2.6	2.4	2.7	2.3	2.6	2.4	2.7	2.3	2.6	2.4	2.7	2.3	2.6	2.4	2.7	2.3	2.6	2.4	2.7
Bucket capacity (struck)	m³	1.984	2.270	2.057	2.346	1.984	2.270	2.057	2.346	1.984	2.270	2.057	2.346	1.984	2.270	2.057	2.346	1.984	2.270	2.057	2.346	1.984	2.270	2.057	2.346
Bucket width	mm	2740	2740	2700	2700	2740	2740	2700	2700	2740	2740	2700	2700	2740	2740	2700	2700	2740	2740	2700	2700	2740	2740	2700	2700
Bucket weight	kg	1151	1224	1163	1236	1124	1199	1136	1211	1151	1224	1163	1236	1124	1199	1136	1211	1151	1224	1163	1236	1124	1199	1136	1211
Maximum material density	kg/m³	2082	1814	1995	1747	1958	1706	1876	1642	1582	1379	1516	1327	1488	1396	1426	1248	1288	1123	1235	1081	1212	1055	1161	1016
Tipping load straight	kg	11467	11310	11467	11310	10828	10676	10828	10676	8715	8595	8715	8595	8229	8114	8229	8114	7247	7148	7247	7148	6843	6747	6843	6747
Tipping load full turn	kg	9578	9436	9578	9436	9009	8870	9009	8870	7279	7171	7279	7171	6847	6741	6847	6741	5929	5841	5929	5841	5576	5490	5576	5490
Payload	kg	4789	4718	4789	4718	4504	4435	4504	4435	3639	3585	3639	3585	3423	3370	3423	3370	2964	2920	2964	2920	2788	2745	2788	2745
Maximum break out force	kN	147	134	147	134	131	122	131	122	147	134	147	134	131	122	131	122	153	139	153	139	136	124	136	127
M Dump angle maximum	degrees	50°	50°	50°	50°	50°	50°	50°	50°	45°	45°	45°	45°	45°	45°	45°	45°	50°	50°	50°	50°	50°	50°	50°	50°
N Roll back angle full height	degrees	58°	58°	58°	58°	58°	58°	58°	58°	60°	60°	60°	60°	60°	60°	60°	60°	58°	58°	58°	58°	58°	58°	58°	58°
O Roll back at carry	degrees	48°	48°	48°	48°	48°	48°	48°	48°	54°	54°	54°	54°	54°	54°	54°	54°	48°	48°	48°	48°	48°	48°	48°	48°
P Roll back at ground level	degrees	43°	43°	43°	43°	43°	43°	43°	43°	45°	45°	45°	45°	45°	45°	45°	45°	43°	43°	43°	43°	43°	43°	43°	43°
Q Load over height	mm	3755	3755	3755	3755	3755	3755	3755	3755	4409	4409	4409	4409	4409	4409	4409	4409	4976	4976	4976	4976	4976	4976	4976	4976
R Dump height (45° dump)	mm	2806	2742	2974	2883	2721	2657	2862	2798	3460	3396	3628	3537	3375	3311	3516	3452	4023	3959	4191	4100	3938	3874	4079	4015
S Dig depth	mm	132	132	106	106	132	132	106	106	127	127	101	101	127	127	101	101	105	105	79	79	105	105	79	79
T Reach at dump height	mm	1148	1207	1044	1103	1225	1283	1121	1179	1148	1207	1044	1103	1225	1283	1121	1179	1172	1231	1068	1127	1249	1307	1145	1230
Pin height	mm	4021	4021	4021	4021	4021	4021	4021	4021	4675	4675	4675	4675	4675	4675	4675	4675	5242	5242	5242	5242	5242	5242	5242	5242
Reach maximum (45° dump) – horizontal arm	mm	1987	2051	1883	1947	1772	2136	1968	2032	2477	2541	2373	2437	2262	2626	2458	2522	2952	3016	2848	2912	2737	3101	2933	2997
Operating weight (includes 80kg operator and full fuel tank)	kg	14491	14564	14503	14576	14788	14863	14800	14875	14981	15054	14993	15066	15278	15353	15290	15365	15533	15606	15545	15618	15830	15905	15842	15917

TYRE SIZE								
436 ZX								
Tyre size	Manufacturer	Type	Rating	Op weight kg	Standard arms		Dimensions	
					STL kg	FTTL kg	Vertical mm	Width mm
20.5 - 25 (crossply)	Firestone		L2	-348	-208	-201	-9	+5
20.5 - 25 (crossply)	Goodyear	SGL	L2	-54	-32	-31	-9	+5
20.5 R 25 (radial)	Goodyear	RL - 2 +	L2	+76	+45	+44	-9	+5
20.5 R 25 (radial)	Bridgestone	VUT	L2	-160	-96	-93	0	0
20.5 R 25 (radial)	Michelin	XTLA	L2	-160	-96	-93	-9	+5
20.5 R 25 (radial)	Bridgestone	VMT	L3	0	0	0	0	0
550/65 R 25 (radial)	Michelin	XLD	L3	-120	-71	-69	0	0
20.5 R 25 (radial)	Michelin	XRD1A	L4	+456	+272	+264	+29	+8
20.5 R 25 (radial)	Michelin	XMINED2	L5	+680	+407	+393	+29	-3
20.5 R 25 (radial)	Goodyear	RL-5K	L5	+600	+358	+347	+29	-3
20.5R25 (radial)	JCB	Earthmover	L3	128	70	60	41	12
20.5-25 (crossply)	JCB	Sitemaster	L3	100	55	47	21	-7
Optional additional bolt-on counterweight				+380	+680	+570	0	0

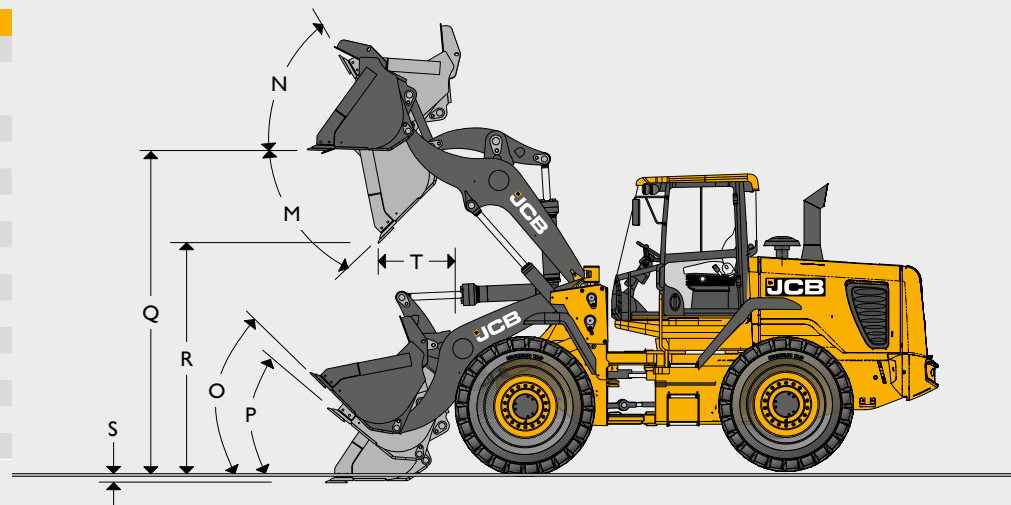

**LOADER DIMENSIONS – 436 ZX**

Assumes the machine is fitted with Michelin 20.5R25 XHA (L3) tyres

Model	436 ZX									
	Bucket mounting	Direct			Quickhitch					
		General purpose		Penetration	General purpose		General purpose			
Bucket type	Tipped teeth			Reversible toeplate		Tipped teeth		Reversible toeplate		
Bucket equipment	Tipped teeth			Reversible toeplate		Tipped teeth		Reversible toeplate		
Bucket capacity (SAE heaped)	m <sup>3</sup>	2.3	2.6	2.6	2.4	2.7	2.3	2.6	2.4	2.7
Bucket capacity (struck)	m <sup>3</sup>	1.984	2.274	2.274	2.057	2.346	1.984	2.274	2.057	2.346
Bucket width	mm	2740	2740	2740	2700	2700	2740	2740	2700	2700
Bucket weight	kg	1250	1317	1361	1262	1329	1124	1199	1136	1211
Maximum material density	kg/m <sup>3</sup>	1999	1744	1752	1913	1676	1908	1664	1811	1600
Tipping load straight	kg	11057	10911	10953	11044	10898	10551	10404	10451	10388
Tipping load full turn	kg	9199	9069	9110	9185	9055	8778	8656	8694	8643
Payload	kg	4599	4535	4555	4592	4527	4389	4328	4347	4321
Maximum break out force	kN	176	162	162	176	162	157	144	157	144
M Dump angle maximum	degrees	47°	47°	47°	47°	47°	47°	47°	47°	47°
N Roll back angle full height	degrees	58°	58°	58°	58°	58°	58°	58°	58°	58°
O Roll back at carry	degrees	45°	45°	45°	45°	45°	45°	45°	45°	45°
P Roll back at ground level	degrees	37°	37°	37°	37°	37°	37°	37°	37°	37°
Q Load over height	mm	3755	3755	3755	3755	3755	3755	3755	3755	3755
R Dump height (45° dump)	mm	2824	2759	2759	2965	2833	2739	2674	2880	2748
S Dig depth	mm	131	131	131	105	105	131	131	105	105
T Reach at dump height	mm	1248	1312	1312	1144	1103	1333	1397	1229	1188
Pin height	mm	4021	4021	4021	4021	4021	4021	4021	4021	4021
Reach maximum (45° dump)	mm	2000	2064	2064	1896	1947	2077	2141	1973	2024
Operating weight (includes 80kg operator and full fuel tank)	kg	14910	14977	15021	14922	14989	15207	15274	15219	15286



ENGINE			
		426	436
Type		4 stroke direct injection	
Model		Cummins BTAA 5.9C	
Capacity	litres	5.9	
Aspiration		Turbo charged	
Cylinders		6	
Max gross power to SAE J1995/ISO 14396	kW (hp) @ 2000rpm	113 (152)	132 (177)
Rated gross power to SAE J1995/ISO 14396	kW (hp) @ 2200rpm	112 (150)	129 (173)
Nett power to SAE J1349/EEC 80/1269	kW (hp) @ 2200rpm	106 (146)	123 (165)
Max torque	Nm @ 1300rpm	633	786
Emissions		Tier 2	

TRANSMISSION			
		426	436
Make and model		ZF 4WG 160 4 Speed	ZF 4WG 190 4 Speed
1st gear	kph	7.4	8.2
2nd gear	kph	14.5	14.5
3rd gear	kph	25.2	27
4th gear (forward only)	kph	37.9	37.9
Torque convertor stall ratio		2.549:1	2.873:1

AXLES			
<b>426</b>			
Type		Open differentials/Limited slip differential	
Make and model		ZF MT-L 3075 II (front) ZF MT-L 3065 II (rear)	
Overall axle ratio		21.53:1	
Rear axle oscillation		21°	
<b>436</b>			
Type		Open differential / Limited slip differential	
Make and model		ZF MT-L3085 II (front) ZF MT-L 3075 II (rear)	
Overall axle ratio		20.184:1	
Rear axle oscillation		21°	

<b>STEERING</b>	Priority steer hydraulic system with emergency steering.
<b>BRAKES</b>	Hydraulic power braking on all wheels, hub mounted, oil immersed, multi-plate disc brakes, parking brake, mechanical type operating on transmission output shaft.
<b>TYRES</b>	A variety of tyre options are available including: 20.5-25 SGG (L2). 20.5-25 SGL (L2). 20.5R25 RL-2+ (L2). 20.5R25 VUT (L2). 20.5R25 XLTA (L2). 20.5R25 VMT (L3). 20.5R25 XHA (L3). 550/65R25 XLD (L3). 20.5R25 XRDIA (L4). 20.5R25 XMINED2 (L5). 20.5R25 RL-5K (L5). 620-75 MEGA XBIB. 750-75 MEGA XBIB.
<b>CAB</b>	426/436 in cab noise level 73Lp

ELECTRICAL SYSTEM			
System voltage	Volt	24	
Alternator output	Amp hour	70	
Battery capacity	Amp hour	2 x 110	

LOADER HYDRAULICS			
		426	436
Pump type		Twin variable displacement piston pumps	
Pump 1 max. flow	l/min	132	132
Pump 1 max. pressure	bar	250	250
Pump 2 max. flow	l/min	132	132
Pump 2 max. pressure	bar	160	160
Hydraulic cycle times at full engine revs		Seconds	
		<b>426</b>	<b>436</b>
Arms raise (full bucket)		4.4	5.9
Bucket dump (full bucket)		1.0 (1.3 ZX)	1.0
Arms lower (empty bucket)		2.7	3.4
Total cycle		8.1 (8.4 ZX)	10.3

SERVICE FILL CAPACITIES			
		426	436
Hydraulic system	litres	210	210
Fuel tank	litres	230	230
Engine oil sump	litres	14	14
Transmission oil system	litres	27	32.5
Axle oil (front)	litres	39	39
Axle oil (rear)	litres	37	39
Engine coolant system	litres	35	35

<b>STANDARD EQUIPMENT</b>	<p><b>Loader:</b> Bucket reset mechanism, loader arm kickout mechanism, loader control isolator, single lever servo control, high torque geometry combines with excellent visibility between the arms.</p> <p><b>Engine:</b> Air cleaner - 2 stage dry type - cyclonic with primary and safety elements, silencer and exhaust stack, sedimenter, twin bowl fuel filters, alternator and compressor drive belt guards. Isolated cooling package with hydraulically driven cooling fan.</p> <p><b>Transmission:</b> Single lever shift control, speed inhibitor, neutral start, disconnect on footbrake and loader lever, disconnect isolator switch, direction changes and kickdown on gear selector and loader control lever.</p> <p><b>Axles:</b> Epicyclic wheel hub reduction, fixed front, oscillating rear.</p> <p><b>Brakes:</b> Multi-plate wet disc brakes, organic linings, dual circuit hydraulic power assisted. Parking disc brake on transmission output shaft.</p> <p><b>Hydraulics:</b> Twin piston pump with priority steer, emergency steer back-up, 2 spool loader circuit with accumulator support, 3rd spool auxiliary hydraulic circuit as standard. Hydraulic tank located in the rear chassis fabrication.</p> <p><b>Steering:</b> Adjustable steering column, "soft feel" steering wheel 5 turns lock to lock, resilient stops on max lock.</p> <p><b>Cab:</b> ROPS/FOPS safety structure, interior reading light, centre mounted master warning light. Electronic monitoring panel with LCD message display. Two speed intermittent front windscreen wipe/wash and self park, single speed rear windscreen wipe/wash and self park. 3 speed heater/demisting with replaceable air filter, LH and RH opening windows, sun visor, sun blind, internal rear view mirror, heated external mirrors, adjustable suspension seat with belt and headrest, operator storage facilities, laminated windscreen, heated rear screen, loader control isolator, horn.</p> <p><b>Electrical:</b> Road lights front and rear, parking lights, front and rear working lights, reverse alarm and light, rear fog light, battery isolator, radio wiring and speakers, 70 amp alternator, rotating beacon.</p> <p><b>Bodywork:</b> Front and rear fenders, side and rear access panels, flexible bottom step, full width rear counterweight, recovery hitch, lifting lugs.</p>
---------------------------	---

<b>OPTIONAL EQUIPMENT</b>	Air conditioning, limited slip differentials front/rear axles, Turbo 2 and dust buster pre-cleaner, tooth guard, replaceable bucket wearparts, epoxy coated radiator/coolers, automatically reversing cooling fan, stainless steel brake pipes, smooth ride system (SRS), hydraulic quickhitch, full rear fenders, reversing camera (colour), additional front and rear worklights, auto greasing system, joystick or Multi-lever hydraulic controls, auxiliary hydraulic control on separate lever or joystick mounted (proportional), Smart reverse alarm, canopy cab, Wastemaster cab, Livelink telematics, widecore radiator, sealed electrics, grease gun and cartridge, basic and full belly guard kits, mesh air intake screen, ARV kit, safety strut, transmission cooler bypass, 24V to 12V in cab converter, cab screen guards, additional front and rear work lights, heated air suspension seat, heated mirrors, extra counterweight, light guards, front and rear blinds, engine block heater, biodegradable hydraulic oil, cab filtration options, fire extinguisher, number plate light kit, auxiliary 4th spool hydraulic service, grease gun, LiveLink telematics.
---------------------------	---

LOADER DIMENSIONS – FORK FRAME WITH FORKS

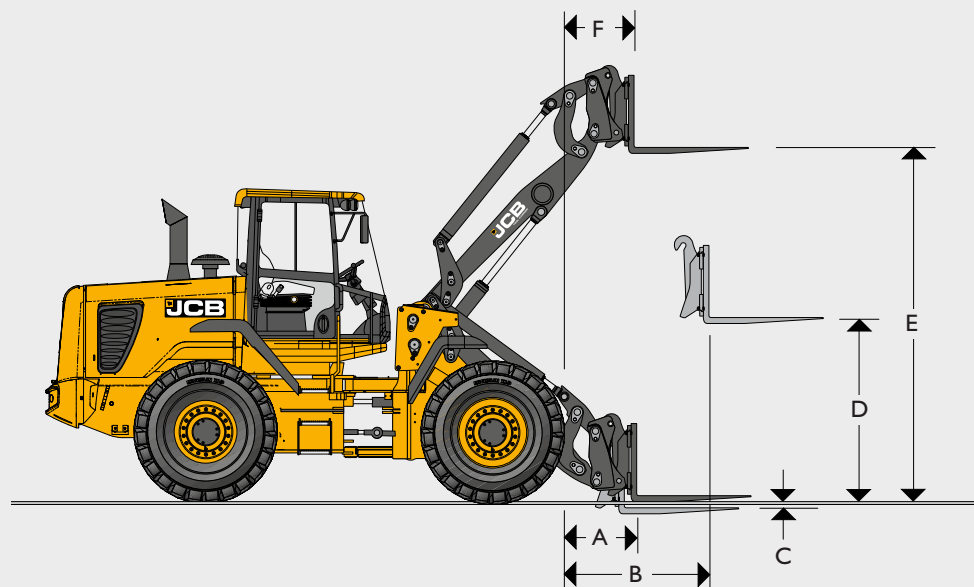

			Standard Height Arm				Hi Lift Arm				Super Hi Lift Arm		ZX Arm	
			Parallel fork		Non parallel fork		Parallel fork		Non parallel fork		Parallel fork	Non parallel fork	426 ZX	436 ZX
Assumes the fitment of Michelin 20.5R25 XHA (L3) tyres			426 HT	436 HT	426 HT	436 HT	426 HT	436 HT	426 HT	436 HT	436 HT	436 HT	426 ZX	436 ZX
	Fork carriage width	mm	1500	1500	1500	1500	1500	1500	1500	1500	1500	1500	1500	1500
	Length of tines	mm	1220	1220	1220	1220	1220	1220	1220	1220	1220	1220	1220	1220
A	Reach at ground level	mm	760	791	770	798	1173	1147	1183	1154	2014	2021	770	798
B	Reach at arms horizontal	mm	1545	1613	1545	1620	1893	2103	1893	2110	2578	2585	1545	1620
C	Below ground level	mm	-52	8	-25	16	11	3	38	11	-19	-11	-42	16
D	Arms, horizontal height	mm	1906	1946	1867	1936	1906	1946	1867	1936	1946	1936	1867	1936
E	Arms, maximum height	mm	3718	3828	3695	3818	4148	4482	4125	4472	5045	5045	3695	3818
F	Reach at maximum height	mm	792	862	800	869	954	862	962	869	886	893	800	869
	Payload*	kg	5000	5000	5000	5000	4518	4650	4518	4650	3599	3599	5260	5610
	Tipping load straight	kg	7571	8589	7571	8589	6587	6871	6587	6871	5428	5428	7722	8289
	Tipping load full turn (40°)	kg	6492	7267	6492	7267	5648	5813	5648	5813	4499	4499	6575	7013
	Attachment weight	kg	440	482	440	482	440	482	440	482	440	440	440	482

\*At the centre-of-gravity distance 500mm. Based on 80% of full turn tipping load as defined by ISO 8313.

Manual fork spacings at 50mm increments. Fork section 100mm x 50mm.



**BUCKET CAPACITIES – 426**

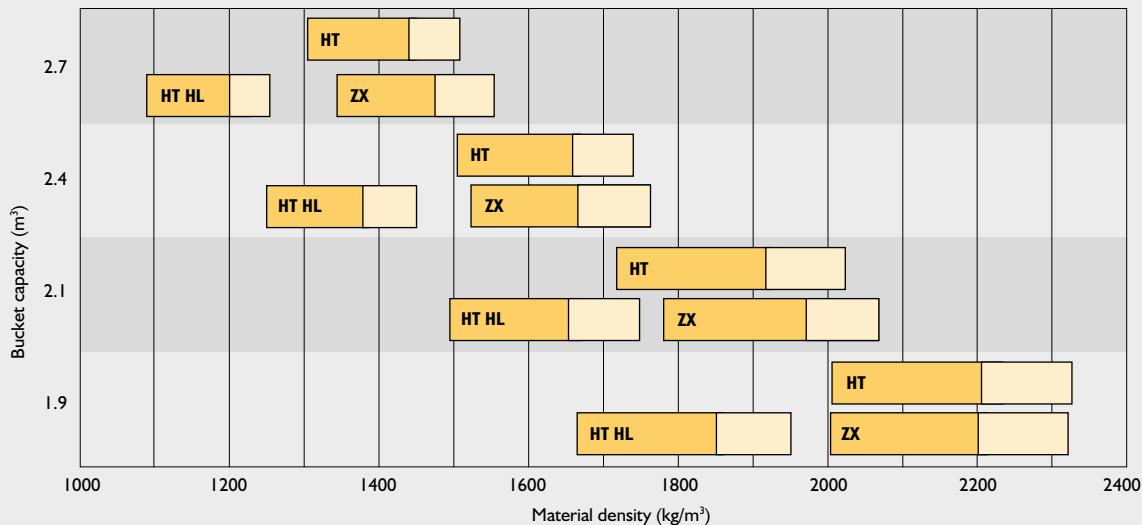

**BUCKET CAPACITIES – 436**

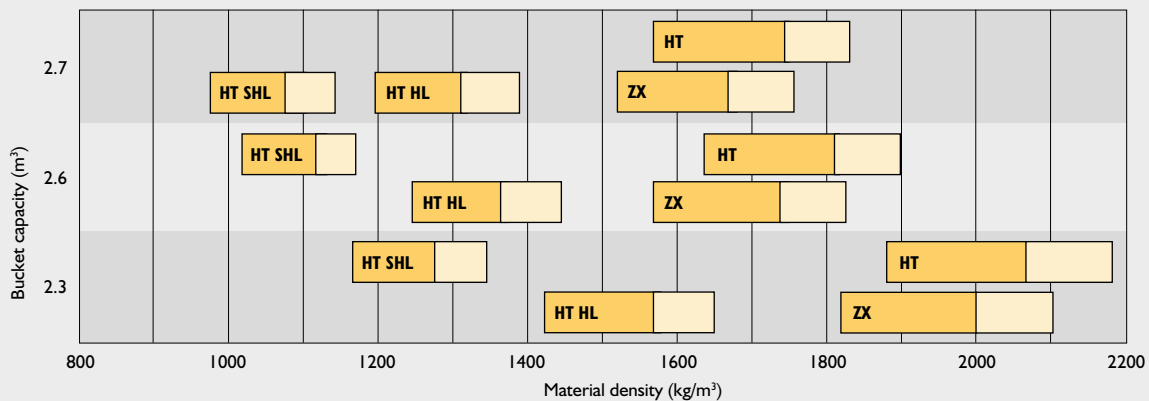

HT = Standard height arm HT HL = High lift arm HT SHL = Super high lift arm ZX = Z-bar

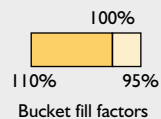

**BUCKET SELECTOR – STANDARD HEIGHT ARM**

Material	Loose density (kg/m³)	Fill factor (%)
Snow (fresh)	200	110
Peat (dry)	400	100
Sugar beet	530	100
Coke (loose)	570	85
Barley	600	85
Petroleum coke	680	85
Wheat	730	85
Coal bituminous	765	100
Fertiliser (mixed)	1030	85
Coal anthracite	1046	100
Earth (dry) (loose)	1150	100
Nitrate fertiliser	1250	85
Sodium chloride (dry) (salt)	1300	85
Cement Portland	1440	100
Limestone (crushed)	1530	100
Sand (dry)	1550	100
Asphalt	1600	100
Gravel (dry)	1650	85
Clay (wet)	1680	110
Sand (wet)	1890	110
Fire clay	2080	100
Copper (concentrate)	2300	85
Slate	2800	100
Magnetite	3204	100



**ONE COMPANY, OVER 300 MACHINES.**

### Wheel Loader 426/436

426 – Gross rated power: 112kW (150hp) Operating weight: 12,740kg

Full turn tipping load: 8,271kg Standard shovel capacity: 2.1m<sup>3</sup>

436 – Gross rated power: 129kW (173hp) Operating weight: 14,564kg

Full turn tipping load: 9,436kg Standard shovel capacity: 2.7m<sup>3</sup>

Your nearest JCB dealer

JCB Sales Limited, Rocester, Staffordshire, United Kingdom ST14 5JP.

Tel: +44 (0)1889 590312 Email: [salesinfo@jcb.com](mailto:salesinfo@jcb.com)

Download the very latest information on this product range at: [www.jcb.com](http://www.jcb.com)

©2009 JCB Sales. All rights reserved. No part of this publication may be reproduced, stored in a retrieval system, or transmitted in any form or by any other means, electronic, mechanical, photocopying or otherwise, without prior permission from JCB Sales. All references in this publication to operating weights, sizes, capacities and other performance measurements are provided for guidance only and may vary dependant upon the exact specification of machine. They should not therefore be relied upon in relation to suitability for a particular application. Guidance and advice should always be sought from your JCB Dealer. JCB reserves the right to change specifications without notice. Illustrations and specifications shown may include optional equipment and accessories. The JCB logo is a registered trademark of J C Bamford Excavators Ltd.



[www.carbonbalancedpaper.com](http://www.carbonbalancedpaper.com)  
unique print number

