

NEW



WHEELED LOADING SHOVEL | 455ZX

Operating weight: 17880kg Gross engine power: 165kW (221hp) Full turn tipping load: 11100 kg Standard shovel capacity: 3.1m³



A QUALITY PROCESS.

PURPOSE-DESIGNED AND BUILT TO COPE WITH THE MOST DEMANDING SITES ON EARTH, THE NEW JCB 455ZX OFFERS PREMIUM QUALITY AND RELIABILITY. THE PROCESSES WE'VE USED IN ITS DESIGN AND MANUFACTURE WILL ENSURE THAT WORK GOES ON HOUR AFTER HOUR, DAY AFTER DAY.



Designed to work hard.

1 We use state-of-the-art manufacturing processes like robot machining, precision paint technology and innovative assembly techniques to achieve the very highest levels of build quality.

2 Finite element analysis and rig testing ensure superior structural strength and durability; to guarantee that the 455ZX will perform anywhere for you, we carry out extreme hot and cold climate testing.

3 Recessed rear lights are protected within the solid counterweight; the counterweight and cast quarter pillars also protect the cooling pack and the back end of the machine from damage.

4 Hoses are neatly routed and clamped through the articulation joint, well away from any pinch points.



Built to last.

5 JCB DIESELMAX engines feature a heavy-duty cast iron cylinder block, bedplate, cylinder head and forged crankshaft to provide high strength and long life.

6 Precision machining provides high tolerances and accurate location of the 455ZX's pins and bushes.

7 There are top quality components fitted to the 455ZX (a JCB DIESELMAX engine, ZF transmission and axles, Rexroth pumps and a Parker valve block, for example), so you can rest assured that you'll get a long, reliable service life from your machine.

8 The articulation joint has a heavy-duty box section (much stronger than a single plate with a boss), a heavy-duty centre pin and oversized bush, as well as twin taper roller bearings on the bottom box joints. This setup can tolerate both vertical and horizontal loadings for durability and rigidity. Steering rams are positioned high up and protected from damage.

9 The JCB Dieselmex 672 is equipped with high capacity multistage fuel filtration designed specifically for reliable operation in territories where fuel quality cannot be guaranteed. This consists of water separation and a unique 3-stage filtration system dealing with water in fuel, fine and large particles as well as increasing capacity for filter life.



5



6



9



PRODUCTIVE PERFORMANCE.

NO MATTER WHERE IN THE WORLD YOU'RE OPERATING, THE NEW JCB 455ZX WILL PERFORM GREAT FEATS OF PRODUCTIVITY. ITS ENGINE OFFERS HIGH POWER AND TORQUE, WHILE ITS HYDRAULICS AND LOADER END ARE SET UP TO KEEP CYCLE TIMES SHORT AND WORKING SHIFTS LONG.

Powering it all.

- 1 A state-of-the-art engine management system offers optimised performance and fuel efficiency at all times.
- 2 The JCB DIESELMAX 672 engine uses our latest generation EcoMAX lean-burn combustion system for ultimate efficiency and reduced emissions. The 6-cylinder 7.2 litre engine achieves high power (165kW) and peak torque (1000Nm) at low revs for excellent response.
- 3 There's a 310-litre fuel tank as standard on the 455ZX, along with extremely fuel-efficient matching of hydraulics, transmission and engine. This combination ensures maximum uptime between refuelling: a welcome feature when you're working in remote areas where diesel has to be transported in.

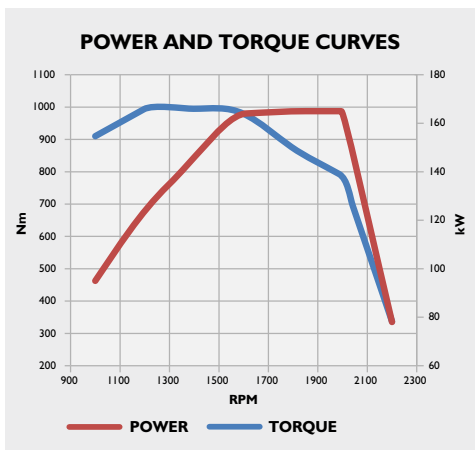

Powerful twin variable displacement piston pump hydraulics can circulate a massive 226 l/min for fast cycles and excellent multi-function capability.

Loading productivity.

- 4 Proven Z-bar loader geometry is capable of exceptional productivity, courtesy of comprehensive penetration into the pile, high breakout forces, good roll-back angles and faster dig times. You'll also benefit from reduced tyre wear and superior fuel efficiency, making this machine a great investment for any business.
- 5 The innovative electronic management system can perform progressive clutch cut-off for efficient, productive loader control. This feature controls tractive effort via the transmission, diverting maximum power to the loader hydraulics and reducing service brake wear and fuel consumption
- 6 The 455ZX is fitted as standard with limited slip differentials that are perfect for soft, muddy terrain with reduced traction.
- 7 The 455ZX's selectable loader arm detents mean operators can set loader arm height limitations, return to dig and float functions for improved safety and productivity.



COMFORTABLY SUPERIOR.

KEEPING OPERATORS FRESH AND ALERT ALL DAY LONG RESULTS IN INCREASED SAFETY AND PRODUCTIVITY. WITH THAT IN MIND, THE NEW 455ZX'S 3M³ CAB IS ROOMY, EASY TO ACCESS AND QUIET. IT ALSO HAS EXCELLENT VISIBILITY AND AN INTUITIVE, ERGONOMIC CONTROL LAYOUT.

Excellent visibility is assured with a 3-piece laminated front screen and interior mirrors, an optional reverse camera and a sloping rear bonnet all help to provide a good rearward view.

A comfortable operator.

1 For maximum operator comfort, the 455ZX is fitted with an easily adjustable tilting and telescopic steering column.

2 A stylish, modern central dash display combines analogue dials and a colour LCD screen – this can display machine health details, service requirements, operating information and more.

3 Optional 3-spool hydraulics enable many attachments to be used easily for extra versatility on your machine.



A good place to work.

6 Air conditioning comes as standard on a JCB 455ZX, ensuring that your operators can create their perfect working temperatures.

6 Internal noise in this all-day-comfy cab measures just 74dBA.

7 Increased ventilation and improved communication on site are provided by sliding windows to each side of the operator.

8 There's plenty of storage behind the rear seat of this machine, keeping the forward operating area uncluttered and safe.

9 Additional storage capacity and security is provided by the lockable tool box on the right-hand step.



LOW MAINTENANCE LONG INTERVALS.

JCB RECOGNISES THAT WHEELED LOADING SHOVELS NEED TO SPEND THE MAXIMUM AMOUNT OF TIME HARD AT WORK FOR YOU. WE'VE THEREFORE DESIGNED THE NEW 455ZX TO DO JUST THAT, WITH LONG SERVICE INTERVALS AND QUALITY COMPONENTS.



Access all areas.

- 1** You can gain access to the 455ZX's engine bay and cooling pack areas easily with wide-opening gullwing doors.
- 2** Daily checks and grease points are accessible from ground level, making life easier and safer for your operators.
- 3** The cooling pack is a single faced unit, allowing excellent access for cleaning.



Looking after itself.

- 4 You can check brake, steering and hydraulic system pressures easily on a 455ZX thanks to grouped test ports.
- 5 Bucket teeth are bolt-on replaceable pieces, making them quick and easy to renew and thus ensuring maximum uptime.
- 6 The 455ZX's electronic monitoring system relays key information and real time alerts, safeguarding both machine and operator.
- 7 Full hydraulic dual circuit braking with multiple oil immersed discs gives the 455ZX's braking system a virtually maintenance-free lifespan.

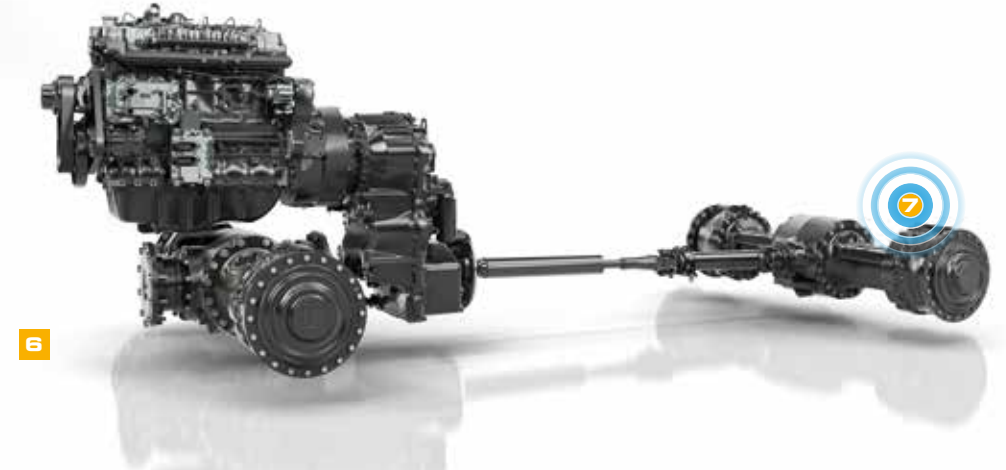

EFFICIENT BY DESIGN.

THE NEW JCB 455ZX IS DESIGNED TO MOVE MORE MATERIAL FOR LESS. TO ACHIEVE THIS, WE'VE BUILT THE ENGINE, AXLES, DRIVELINE AND HYDRAULICS TO WORK IN PERFECT HARMONY WITH EACH OTHER FOR ULTIMATE EFFICIENCY.



Access all areas.

- 1 The float mode on the 455ZX's valve block lowers the loader arms under gravitation – not hydraulic – force, reducing fuel consumption.
- 2 Wheel speed braking means the brakes rotate at the same speed as the wheels for heat and drag reduction, as well as improved fuel economy.
- 3 A hydraulic cooling fan automatically reacts to ambient temperature and adjusts the 455ZX's fan speed to optimise cooling and reduce fuel consumption. This feature also lowers noise levels.
- 4 JCB's innovative variable displacement pumps feed a load-sensing valve block which only consumes power on demand, providing precise, efficient loader control.



DRIVE SAFELY.

IT'S ESSENTIAL TO KEEP WORKSITES SAFE AT ALL TIMES SO THE NEW JCB 455ZX OFFERS GREAT VISIBILITY, NON-SLIP SURFACES, AIR FILTRATION AND MANY MORE FEATURES TO PROTECT YOUR MACHINERY, YOUR OPERATORS AND BYSTANDERS ALIKE.

Safety first.

- 1 Access steps are inclined and equally spaced, complemented by well positioned grab handles for three points of contact at all times.
- 2 Interior mirrors, heated exterior mirrors and bonnet mirrors combine to provide superb all-round visibility.
- 3 Non-slip walkways and additional grab handle options allow operators to move around the exterior of the machine safely.

The 455ZX's cab is isolated from the chassis by rubber mounts, which keeps noise and vibration levels to a minimum. It's also compliant with ROPS/FOPS standards, and positively pressurised against dust.

- 4 Our optional rear-view camera displays an unobstructed rear view on an in-cab colour monitor.



LIVELINK, WORK SMARTER.

LIVELINK IS AN INNOVATIVE SOFTWARE SYSTEM THAT LETS YOU MANAGE JCB MACHINES REMOTELY – ONLINE, BY EMAIL OR BY MOBILE PHONE. ACCESS EVERYTHING FROM MACHINE ALERTS TO FUEL REPORTS AND HISTORY INFORMATION, WITH ALL DATA STORED AT A SECURE CENTRE.

Productivity and cost benefits

By providing information like idle time monitoring and machine fuel consumption, JCB Livelink helps reduce your fuel usage, saving money and improving productivity. Machine location information can help improve efficiency and perhaps even reduce insurance costs.

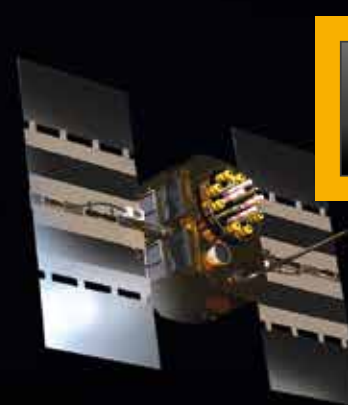

Maintenance benefits

Manage machine maintenance easily – accurate hours monitoring and service alerts improve maintenance planning, while real-time location data helps you manage your fleet. Critical machine alerts and maintenance history records are also available.



Security benefits

Livelink's real-time geofencing alerts tell you when machines move out of predetermined zones, and real-time curfew alerts inform you of unauthorised usage. Further benefits include real-time location information.



VALUE ADDED.

JCB'S WORLDWIDE CUSTOMER SUPPORT IS FIRST CLASS. WHATEVER YOU NEED AND WHEREVER YOU ARE, WE'LL BE AVAILABLE QUICKLY AND EFFICIENTLY TO HELP MAKE SURE YOUR MACHINERY IS PERFORMING TO ITS FULL POTENTIAL.



1 Our Technical Support Service provides instant access to factory expertise, day or night, while our Finance and Insurance teams are always on hand to provide fast, flexible, competitive quotes.

2 The global network of JCB Parts Centres is another model of efficiency; with 16 regional bases, we can deliver around 95% of all parts anywhere in the world within 24 hours. Our genuine JCB parts are designed to work in perfect harmony with your machine for optimum performance and productivity.



3 JCB Assetcare offers comprehensive extended warranties and service agreements, as well as service-only or repair and maintenance contracts. Irrespective of what you opt for, our Maintenance teams around the world charge competitive labour rates, and offer non-obligation quotations as well as fast, efficient insurance repair work.



Note: JCB LIVELINK and JCB ASSETCARE may not be available in your region, so please check with your local dealer.

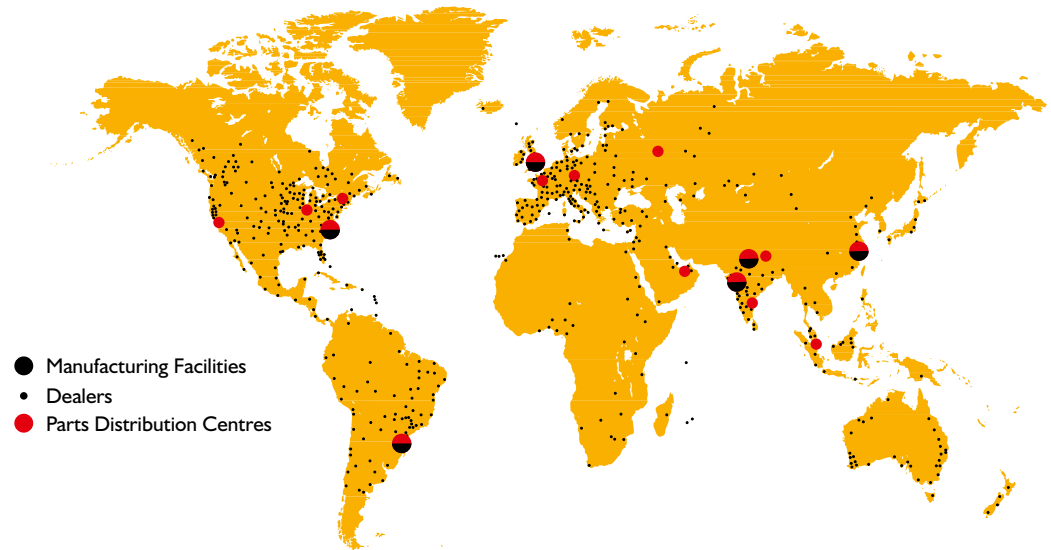

STATIC DIMENSIONS

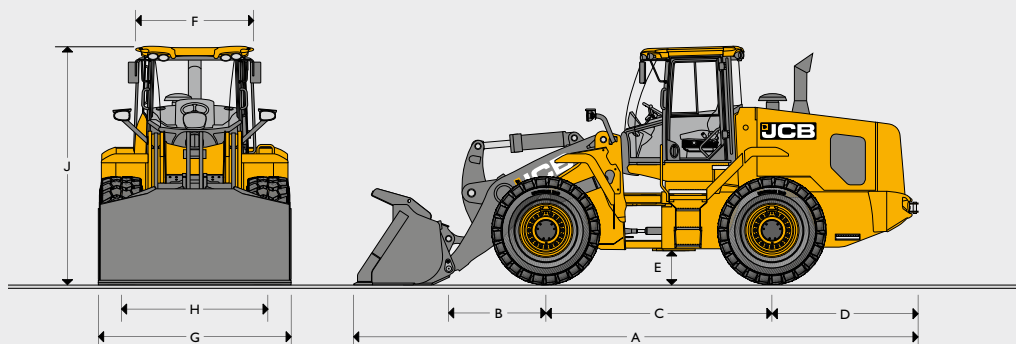

A	Overall length	mm	7984
B	Axle to pivot pin	mm	1622
C	Wheel base	mm	3300
D	Axle to counterweight face	mm	1994
E	Minimum ground clearance	mm	470
F	Width over cab	mm	1400
G	Width over tyres	mm	2702
H	Wheel track	mm	2100
J	Height over cab	mm	3370
	Front axle weight	kg	8204
	Rear axle weight	kg	9596
	Total weight	kg	17800
	Inside turn radius	mm	3211
	Maximum turn radius over shovel	mm	6554
	Articulation angle	deg	±40

Data based on machine equipped with direct mounted 3.1 m³ bucket with toe plates and bolt on teeth and 23.5- 25 R25 BKT L3.

ENGINE

Type	Common Rail Direct Injection (CRDI), Water cooled diesel engine	
Model	JCB DIESELMAX 672	
Capacity	litres	7.2
Aspiration	Turbocharged and after cooler	
Cylinders	6	
Max gross power to SAE J1995/ISO 14396	kW (hp)	165 (221)
Max torque	Nm @ 1500rpm	1000
Emissions	Tier 2	

TRANSMISSION

Type	ZF	
Model	4WG190	
	Forward	Reverse
1	kph	6.5
2	kph	12.8
3	kph	23.77
4	kph	36.04

AXLES

Type	Limited slip differential
Make and model	ZF MTL 3095 II Front ZF MTL 3085 II Rear
Overall axle ratio	23.333
Rear axle oscillation	± 12.5°
Bias Ratio	30%

STEERING

Hydraulic power steering.

BRAKES

Hydraulic power braking on all wheels. In-board mounted, oil immersed, multi-plate disc brakes. Parking brake, electro-hydraulic disc type operating on transmission output shaft.

LOADER DIMENSIONS

Shovel mounting		Direct
Shovel type		General purpose
Shovel equipment		Tipped teeth penetration
Shovel capacity (sae heaped)	m ³	3.1
Shovel capacity (struck)	m ³	2,791
Shovel width	mm	2800
Shovel weight	kg	1613
Maximum material density	kg/m ³	1790
Tipping load straight	kg	12276
Tipping load full turn	kg	11100
Payload	kg	5550
Maximum breakout force	kN	164
M Dump angle maximum	degrees	45
N Roll back angle full height	degrees	67
O Roll back at carry	degrees	45
P Roll back at ground level	degrees	39
Q Load over height	mm	3822
R Dump height (45 deg dump)	mm	2741
S Dig depth	mm	74
T Reach at dump height	mm	1183
V Pin height	mm	4107
Reach maximum (45 deg dump) horizontal arm	mm	2140
Operating weight (includes 80kg operator and full fuel tank (includes aux tank))	kg	17880

Model (loader dimensions quoted on 23.5- 25 R25 BKT L3)

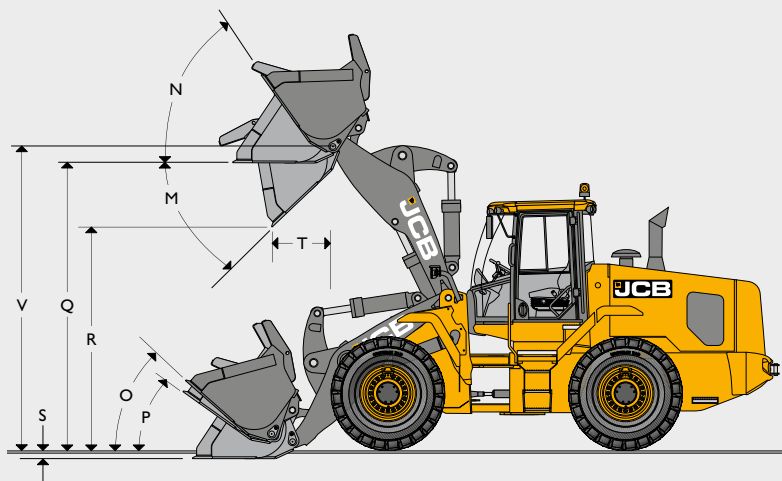

TYRE SIZE

Tyre size	Manufacturer	Type	Operating weight (kg)	Dimensions	
				Vertical (mm)	Width (mm)
23.5x25-20PR (bias) (standard fit)	BKT	L3	17800	0	0
23.5R25 (radial) (optional fit)	BKT	E3/L3	17954	12	0

ELECTRICAL SYSTEM

System voltage	Amps	24
Alternator output	Amps	100
Battery capacity	Amp hour	110

HYDRAULICS

		Variable displacement piston pump-load sensing
Pump type		
Pump 1 max. flow	l/min	132
Pump 1 max. pressure	bar	250
Pump 2 max. flow	l/min	94
Pump 2 max. pressure	bar	310
Hydraulic cycle times at full engine rpm		
Arms raise (full bucket)	Seconds	6.0
Bucket dump (full bucket)	Seconds	1.9
Arms lower (empty bucket)	Seconds	3.7
Total cycle	Seconds	11.6

SERVICE FILL CAPACITIES

Hydraulic tank	litres	180
Fuel tank	litres	310
Engine oil sump	litres	28
Transmission oil system	litres	36
Axle oil (front)	litres	35
Axle oil (rear)	litres	35
Engine coolant system	litres	37

CAB In-cab noise level – 74dB(A).

STANDARD EQUIPMENT

3.1 m³ bucket, 2 spool hydraulics, proportional fan control, 23.5-25 - 20PR L3 tyres, 4 speed transmission, AC cabin, return to dig, boom kickout, 24V socket in cabin, sun visor, interior mirror, LH+RH rear view mirror, front light guard, tail lamp guard, LiveLink (territory dependent), beacon, 12 V converter, cigarette lighter.



ONE COMPANY, OVER 300 MACHINES.

Your nearest JCB dealer

Wheeled Loading Shovel 455ZX

Operating weight: 17880kg Gross engine power: 165kW (221hp)

Full turn tipping load: 11100kg Standard shovel capacity: 3.1m³

JCB Sales Limited, Rocester, Staffordshire, United Kingdom ST14 5JP.

Tel: +44 (0)1889 590312 Email: salesinfo@jcb.com

Download the very latest information on this product range at: www.jcb.com

©2009 JCB Sales. All rights reserved. No part of this publication may be reproduced, stored in a retrieval system, or transmitted in any form or by any other means, electronic, mechanical, photocopying or otherwise, without prior permission from JCB Sales. All references in this publication to operating weights, sizes, capacities and other performance measurements are provided for guidance only and may vary dependant upon the exact specification of machine. They should not therefore be relied upon in relation to suitability for a particular application. Guidance and advice should always be sought from your JCB Dealer. JCB reserves the right to change specifications without notice. Illustrations and specifications shown may include optional equipment and accessories. The JCB logo is a registered trademark of J C Bamford Excavators Ltd.

