



WHEEL LOADER | 406

Max. Engine power: 36.4kW (49hp) Max. Operating weight: 5020kg Full turn tipping load: 3250kg Standard shovel capacity: 0.8m³



PRODUCTIVE PERFORMANCE.

THE JCB 406 IS A HIGHLY PRODUCTIVE WHEELED LOADER WITH OPTIMAL POWER-TO-WEIGHT RATIO, MAKING IT THE PERFECT TOOL CARRIER. IT'S A PERFECT CHOICE FOR RENTAL FLEETS LOOKING FOR A LOW COST, SIMPLE, PRODUCTIVE MACHINE.

JCB Diesel by Kohler.

1 JCB has worked in close collaboration with Kohler to produce the ultimate compact wheel loader engine. No engine power is wasted on a DPF and, with peak power and torque produced at low revs, you get good fuel economy too. Our design also makes dimensions compact for small turning circles.

2 The 406 has an easy-maintenance mechanical JCB Diesel engine by Kohler offering potent performance.

3 JCB standard hydraulic quickhitch makes attachment changing quick and efficient.



Hydrostatic drive makes the 406 very easy to operate even for the inexperienced.



Moving with the times.

6 JCB's articulated steering boasts an easy-to-use built-in sideshift – ideal for pallet handling and changing attachments.

6 So that you can tailor your wheeled loader to any application, we offer limited slip diffs that excel on soft muddy terrain.

7 Power from the driveline is transferred to the ground very efficiently through an innovative chassis, with perfect harmony between all components. This makes our machines the best possible wheeled loader solution.

Versatility by the bucketload.

8 By splitting power between the transmission and the hydraulics, our inching pedal allows precise, efficient, stepless load handling.

8 3 or 4 spool hydraulics enable many attachments to be used for extra versatility.



QUALITY, RELIABILITY AND DURABILITY.

AT JCB, WE UNDERSTAND THAT A WHEEL LOADER IS A KEY PART OF ANY ON-SITE PROCESS. THAT'S WHY THE 406 IS BUILT ON A FOUNDATION OF QUALITY AND RELIABILITY, ENSURING THAT THEY'LL ALWAYS BE A KEY PART OF YOUR WORKING PROCESS.

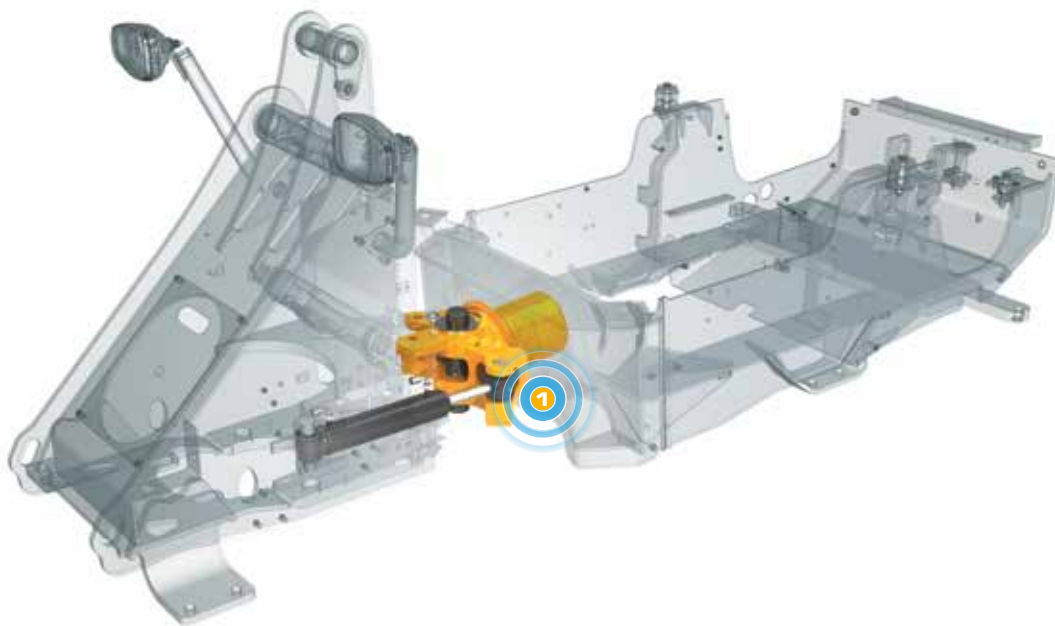

We've used only the very finest engine, driveline and axle components from suppliers like DANA and Bosch.

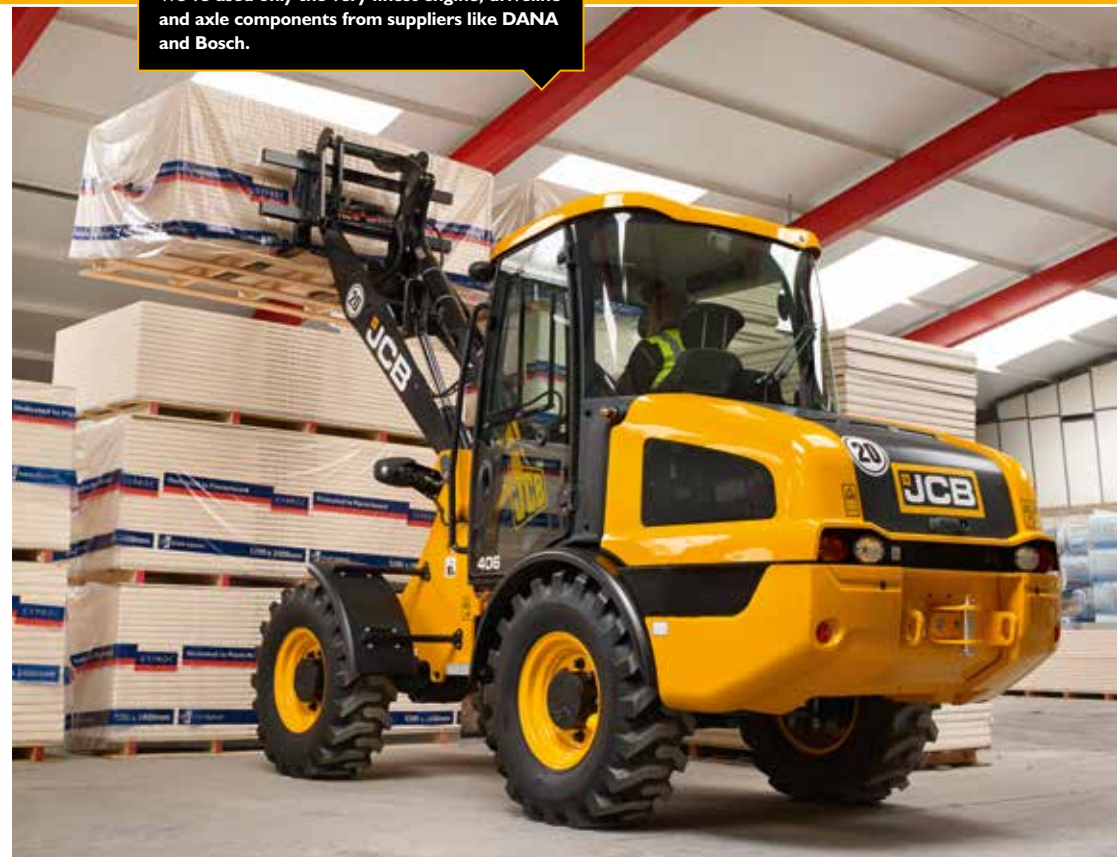

Built to last.

1 We understand how tough materials handling can be, so our machines are developed to be highly durable. A case in point is our heavy-duty centre joint, which oscillates through $\pm 10^\circ$.

2 These machines benefit from a strong chassis and the best possible weight distribution; this allows for the best possible absorption of external forces.



Quality design.

- 3 The rear lights are recessed within the solid counterweight casting for good impact protection.
- 4 Hydraulic hoses are always well protected; they're neatly routed, properly clamped, and positioned well away from potential pinching spots.
- 5 We use state-of-the-art manufacturing processes like robot machining, precision paint technology and innovative assembly techniques to achieve the very highest levels of quality.
- 6 Precision machining provides high tolerances and accurate location of pins and bushes.
- 7 Finite element analysis and rig testing ensure superior structural strength and durability. Cold cell testing guarantees starting performance at temperatures as low as -20°C.



COMFORT AND EASE OF USE.

JCB COMPACT WHEEL LOADERS LIKE THE 406 ARE DESIGNED TO MAKE WORK MORE STRAIGHT FORWARD. THEY'RE EASY TO ACCESS, INTUITIVE TO OPERATE, AND THEY'RE OPERATED FROM THE CENTRE OF THE MACHINE FOR SUPERB VISIBILITY. AFTER ALL, A COMFORTABLE, CONFIDENT OPERATOR IS A MORE PRODUCTIVE ONE.

A comfortable operator.

- 1 The JCB 406 benefits from a comfortable and spacious cab. The operating position is designed for optimum all-round visibility, unhindered by components like silencers.
- 2 Our tilting telescopic steering column is easy to adjust for an ergonomic driving position.
- 3 All the instruments needed to operate a JCB wheeled loader are within easy reach of the seat, so there's no need to hunt around for information whilst working.
- 4 With a fully opening right-hand window operators can enjoy increased ventilation whilst still being protected from dust.
- 5 These compact wheel loaders are equipped with a new ergonomically designed joystick control system for comfortable and intuitive operation.

In-cab noise levels on these machines are lower than outgoing models.



SERVICEABILITY.

A WHEEL LOADER NEEDS TO SPEND AS MUCH TIME AS POSSIBLE HARD AT WORK. THAT'S WHY THE JCB 406 BENEFITS FROM INNOVATIVE DESIGN AND QUALITY COMPONENTS, ALLOWING IT TO OFFER MAXIMUM UPTIME WITH LONG SERVICE INTERVALS.

Access all areas.

- 1 Our large single piece bonnet ensures quick and convenient access to the engine bay and cooling pack areas of your wheel loader. All daily check points are easily accessed under the bonnet.
- 2 Simple analogue in-cab display provides running hours, fuel status and error alerts.
- 3 There's a traditional cylinder-type air filter that's perfectly sized for the smaller engine, ensuring robust and cost-effective performance.
- 4 Your local JCB dealer will be able to supply all parts for your 406, even JCB Diesel by Kohler engine components. The machine also shares parts with other JCB machinery, which makes everything even more readily available.



SAFETY AND SECURITY.

BECAUSE SAFETY AND SECURITY ARE PARAMOUNT ON ANY SITE, THE JCB 406 IS DESIGNED TO PROTECT ITS OPERATORS, THEMSELVES, AND ANY BYSTANDERS AT ALL TIMES. GREAT VISIBILITY, ANTI-THEFT FEATURES AND NON-SLIP SURFACES ARE JUST THE START.

Safety first.

The 406 can be equipped with an immobiliser option, which can help prevent thefts from your fleet.

1 With no exhaust after treatment, our JCB Diesel by Kohler engines are extremely compact, so there's no compromise to visibility. The sloping rear bonnet provides an unimpeded view, with the exhaust silencer and air intake filter both packaged out of sight.

2 We've fitted an in-cab electronic 2-stage quickhitch isolation system to prevent uncontrolled release of attachments.

3 The access step is complemented by well positioned handles so that operators have three points of contact whenever they're entering or exiting the cab.



LIVELINK, WORK SMARTER.

JCB LIVELINK IS AN INNOVATIVE SOFTWARE SYSTEM THAT LETS YOU MONITOR AND MANAGE YOUR MACHINES REMOTELY – ONLINE, BY EMAIL OR BY MOBILE PHONE.

Productivity and cost benefits –

Machine location information can improve fleet efficiency and you may even enjoy reduced insurance costs courtesy of the added security that LiveLink brings.

** Note: Please consult your local dealer for LiveLink availability*



Maintenance benefits – Accurate hours monitoring, maintenance history records, critical machine alerts and service alerts improve maintenance planning.

Security benefits – Real-time geofencing lets you set operating zones and curfew alerts that tell you when your machinery outside of pre-determined times. Location information helps you store machines safely.

VALUE ADDED.

JCB'S WORLDWIDE CUSTOMER SUPPORT IS FIRST CLASS. WHATEVER YOU NEED AND WHEREVER YOU ARE, WE'LL BE AVAILABLE QUICKLY AND EFFICIENTLY TO HELP MAKE SURE YOUR MACHINERY IS PERFORMING TO ITS FULL POTENTIAL.



1 Our Technical Support Service provides instant access to factory expertise, day or night, while our Finance and Insurance teams are always on hand to provide fast, flexible, competitive quotes.

JCB Assetcare offers comprehensive extended warranties and service agreements, as well as service-only or repair and maintenance contracts. Irrespective of what you opt for, our Maintenance teams around the world charge competitive labour rates, and offer non-obligation quotations as well as fast, efficient insurance repair work.



2 The global network of JCB Parts Centres is another model of efficiency; with 16 regional bases, we can deliver around 95% of all parts anywhere in the world within 24 hours. Our genuine JCB parts are designed to work in perfect harmony with your machine for optimum performance and productivity.

Note: JCB LIVELINK and JCB ASSETCARE may not be available in your region, so please check with your local dealer.

STATIC DIMENSIONS

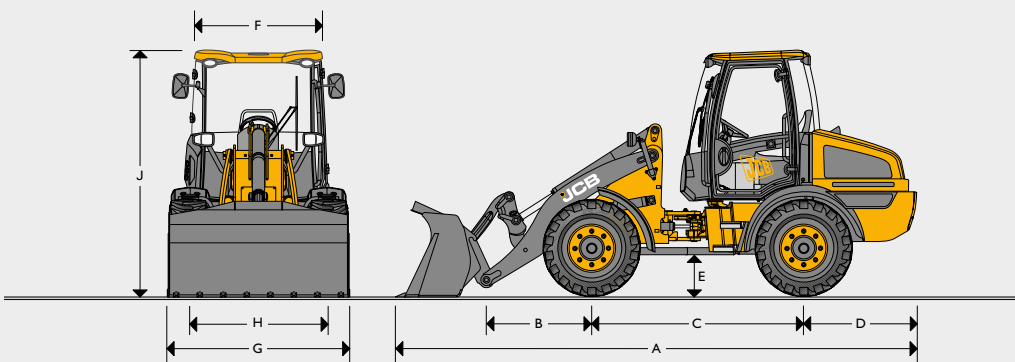

A	Overall Length	mm	5133
B	Axle to pivot pin	mm	906
C	Wheel Base	mm	2100
D	Axle to counterweight face	mm	1268
E	Ground clearance	mm	313
F	Width over cab	mm	1468
G	Width over tyres	mm	1727
H	Wheel track	mm	1390
J	Height Over Cab	mm	2500
	Front axle weight	kg	1475
	Rear axle weight	kg	3398
	Total weight	kg	4873
	Inside Turn Radius	mm	2010
	Maximum Turn Radius over Shovel	mm	4160
	Articulation Angle	deg	±40°
	Maximum radius over tyre	mm	3800
	Max. width across tyres	mm	1761

Data based on machine equipped with pin mounted 0.8m³ bucket with toe plates and Camso SLR4 12.5-18 tyres.

ENGINE

Type	4 stroke, Mechanical	
Model	JCB Diesel by Kohler - KDI 2504 M	
Capacity	litres	2.482
Aspiration	Normally aspirated	
Cylinders	4	
Max gross power to SAE J1995/ISO 14396	kW (hp)	36.4 (49) @ 2600rpm
Max torque	Nm @ 1500rpm	170
Emissions	Stage IIIA	

TRANSMISSION

Type	Hydrostatic		
Model	Rexroth A6VM1 – 2 speed		
Low range	kph	6	
High range	kph	20	

LOADER DIMENSIONS

Model (assumes machine is fitted with Camso SLR4 12.5-18 tyres)						
Bucket type		General purpose	General purpose	Light duty	Light duty	6-in-1 clam shovel
Bucket equipment		Teeth or toeplate		Toeplate		Teeth or toeplate
Bucket capacity (SAE heaped)	m ³	0.8	1	1.2	1.4	0.75
Bucket width	mm	1900	1900	1900	1900	1900
Bucket weight	kg	287	322	353	384	435
Maximum material density	kg/m ³	2050	1620	1320	1120	2100
Tipping load straight	kg	4225	4148	4055	4014	4033
Tipping load full turn	kg	3250	3191	3120	3088	3102
Payload	kg	1625	1595	1560	1544	1551
Maximum breakout force	kN	41.9	36.5	32.2	29.7	41.9
M	Dump angle maximum	degrees	45	45	45	45
N	Roll back angle full height	degrees	56	56	56	56
O	Roll back at carry	degrees	54	54	54	54
P	Roll back at ground level	degrees	42	42	42	42
Q	Load over height	mm	2991	2991	2991	2991
R	Dump height (45 deg dump)	mm	2489	2418	2348	2295
S	Dig depth	mm	105	105	105	105
T	Reach at dump height	mm	764	835	905	958.5
	Reach maximum (45deg dump) – horizontal arm	mm	1494	1465	1635	1689
	Operating weight (includes 80Kg operator and full fuel tank)	kg	4873	4907	4938	4969
V	Pin height	mm	3120	3120	3120	3120

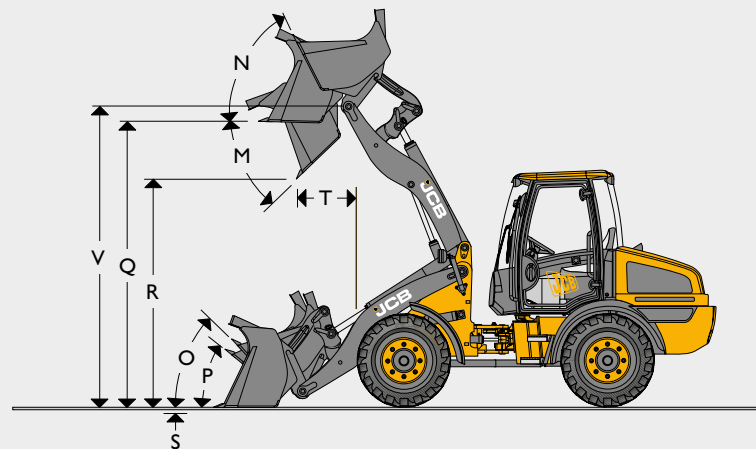

TYRE SIZE					
Tyre size	Manufacturer	Type	Operating weight (kg)	Dimensions	
				Vertical (mm)	Width (mm)
335/80 R18	Dunlop	SPT9 EM	41.2	-4	0
365/70 R18	Dunlop	SPT9 EM	64	-14	69
405/70 R18	Dunlop	SPT9 EM	94	9	113
335/80 R20	Dunlop	SPT9 MPT	77.6	22	-22
340/80 R18	Michelin	XMCL	71.6	28	25
340/80 R18	Michelin	BIBLOAD	65.6	-15	13
12.5-18	Mitas	MPT-04	31.6	9	-6
340/80 R18	Nokian	TRI 2	55.6	6	12
12.5/80-18	Camso	SLR4	0	1	-15
400/70 R18	Trelleborg	TH400	111.6	-15	137

Loader dimensions quoted on Camso SLR4 12.5-18 tyres.

LOADER DIMENSIONS – FORK FRAME WITH FORKS

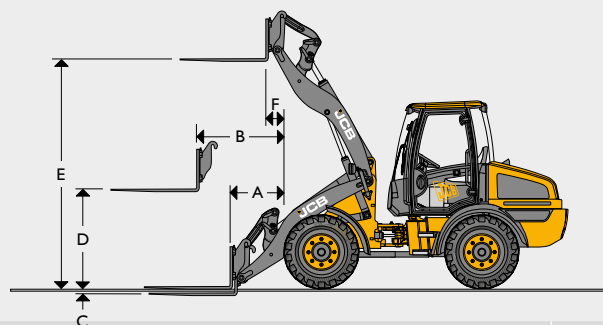

		Parallel fork
Fork carriage width	mm	1345
Length of tines	mm	1200
A Reach at ground level	mm	710
B Reach at arms horizontal	mm	1232
C Below ground level	mm	84
D Arms, horizontal height	mm	1426
E Arms, maximum height	mm	3012
F Reach at maximum height	mm	506
Payload*	kg	2033
Tipping load straight	kg	3184
Tipping load full turn (40°)	kg	2541
Attachment weight	kg	191

*At the centre of gravity distance 500mm. Based on 80% of FTTL as defined in ISO 8313. Manual fork spacings at 50mm increments. Fork section 100mm x 50mm.

AXLES	
Type	Straight beam
Make and model	Dana 111
Chassis angle oscillation	degrees ± 10

STEERING	
	Hydraulic power steering system emergency steering.

ELECTRICAL SYSTEM		
System voltage	Volt	12
Alternator output	Amp hour	80
Battery capacity	Amp hour	100

HYDRAULICS		
Pump type		Tandem Gear Pump
Pump max. flow	l/min	64
Pump max. pressure	bar	230
Auxiliary flow	l/min	60
Hydraulic cycle times at max. engine		
Arms raise (full bucket)	Seconds	4.9
Bucket dump (full bucket)	Seconds	3.5
Arms lower (empty bucket)	Seconds	3.1
Total cycle	Seconds	11.5

SERVICE FILL CAPACITIES		
Hydraulic system	litres	70
Fuel tank	litres	80
Engine oil sump	litres	11.2
Axle oil (front)	litres	4.4
Axle oil (rear)	litres	6.05

STANDARD EQUIPMENT	
GENERAL MACHINE FEATURES	Parallel lift geometry, JCB Hydraulic Quickhitch, articulated steering, front and rear fenders, one piece opening bonnet, recovery hitch, lifting lugs.
TRANSMISSION	Two speed, neutral start, inching function, forward/reverse switch on joystick control lever.
BRAKES	In board oil immersed brakes with combined handbrake; cable operated parkbrake.
ELECTRIC	Full Road Lighting, Direction Indicators and Battery Isolator.
HYDRAULICS	Single lever manual control, gear pump with priority steer, emergency steer back up.
CAB	ROPS/FOPS safety structure, fully adjustable seat, interior light, adjustable tilt steering column, safety glass, front and rear screen wash/wipe, 3 speed heater fan with replaceable filters, sun visor.

OPTIONAL EQUIPMENT	
HBCV, 4th Spool aux circuit manual, LSD axles, fully opening RH window with lock back, immobiliser, livelink, under bonnet battery isolator, worklights, bio oil, shovel level indicator, stowage box. See dealer for full list.	

NOISE AND VIBRATION				
			Uncertainty	Measurement conditions.
Noise at the operator station	LpA	77 dB	+/- 1 dB	Determined in accordance with the test method defined in ISO 6396 and the dynamic test condition defined on 2000/14/EC.
Noise emission from the machine	LWA	101 dB	+/- 1 dB	Guaranteed equivalent sound power (external noise) determined in accordance with the dynamic test conditions defined in 2000/14/EC.
Whole body vibration	m/s ²	0.59	+/- 0.11 dB	ISO 2632-1:1997 normalised to an 8h reference period and based upon a test cycle comprising of loader work (soil).
Hand-arm vibration	m/s ²	<2.5	N/A	ISO 5349-2:2001 dynamic test conditions.

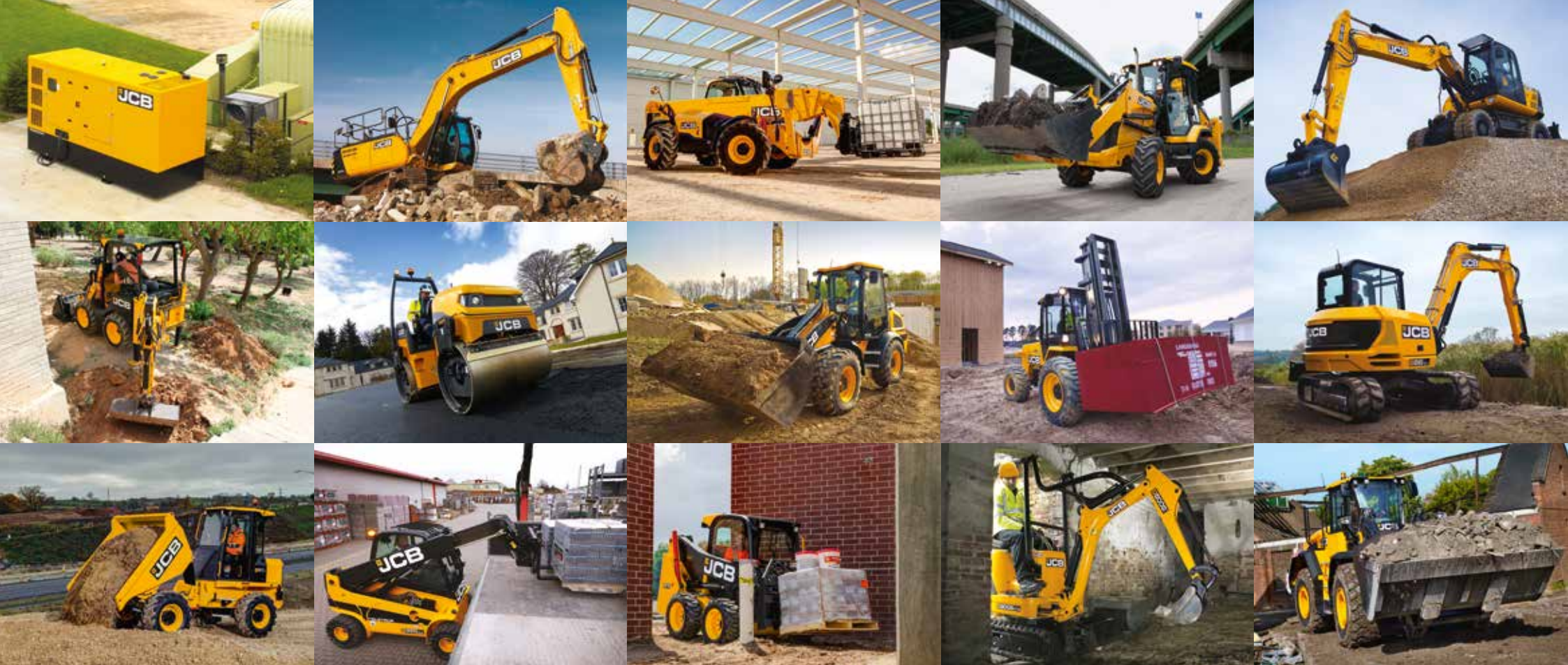

ONE COMPANY, OVER 300 MACHINES.

Your nearest JCB dealer

Wheel Loader 406

Max. Engine power: 36.4kW (49hp) Max. Operating weight: 5020kg
 Full turn tipping load: 3250kg Standard shovel capacity: 0.8m³

JCB Sales Limited, Rocester, Staffordshire, United Kingdom ST14 5JP.
 Tel: +44 (0)1889 590312 Email: salesinfo@jcb.com
 Download the very latest information on this product range at: www.jcb.com

©2009 JCB Sales. All rights reserved. No part of this publication may be reproduced, stored in a retrieval system, or transmitted in any form or by any other means, electronic, mechanical, photocopying or otherwise, without prior permission from JCB Sales. All references in this publication to operating weights, sizes, capacities and other performance measurements are provided for guidance only and may vary dependant upon the exact specification of machine. They should not therefore be relied upon in relation to suitability for a particular application. Guidance and advice should always be sought from your JCB Dealer. JCB reserves the right to change specifications without notice. Illustrations and specifications shown may include optional equipment and accessories. The JCB logo is a registered trademark of J C Bamford Excavators Ltd.

9999/5906 en-GB 02/19 Issue 2

