

Series V

4x2
4x4

Rigid Hauler Tractors

I406A 4x2 | I406AF 4x4
I736A 4x2 | I736AF 4x4

Tier III Certified



BELL

ENGINE

Model
John Deere 6068HF285

Configuration
Six-cylinder, in-line

Emission Certification
Tier III/Stage IIIA

Aspiration
Turbo charged & A/A intercooled

Displacement
6.8 Litre

Gross Power
139 hp / 104 kW

Torque Rise
32%

Governed Engine Speed
2 200 rpm

Maximum torque (Net, Nm @ RPM)
598 Nm @ 1 500 rpm

Compression ratio
19:1

Engine/Transmission Cooling
Custom built high debris tolerant cooling pack with wide spacing. Transmission cooler mounted side by side with the radiator and the CAC.

Engine Exhaust/Retardation
Rectangular canister silencer integrated in line in the exhaust system/Engine valve J - brake.

Engine Air Cleaner
Dual Stage air filter with heavy duty pre-cleaner.

TRANSMISSION

Model
Allison #2500

Torque Converter Layout
Hydrodynamic with lock-up in 1-6 gears and converter mode in gears 1 & 2.

TRANSFER CASE

Model
1406A: N/A
1406AF: Bell

Layout
1406A: N/A
1406AF: Mounted off the rear differential

REAR AXLE

Bell structural steel 13 ton axle

Static Load Rating
32 500 kg

Dynamic Load Rating
13 000 kg

FRONT AXLE

1406A: Bell
1406AF: Carraro cast iron, steering axle, centre pivot, side input

Static Load Rating

1406A: 7 590 kg
1406AF: 5 750 kg

Dynamic Load Rating

1406A: 3 600 kg
1406AF: 3 600 kg

STEERING SYSTEM

Single steering cylinder with through-rod and adjustable tie-rod ends.

BRAKING SYSTEM AND BRAKING FORCE

Service Brake
Rear axle braking only

Park brake
Rear axle braking only

Specification Compliance
SANS 1447-1:2007 Ed.2

Pneumatic System Charge Pressure
8,5 bar

Park Brake Type
Spring applied and pneumatic released

WHEELS

1406A Wheels
600/65R38
315/80R22.5

1406AF Wheels
420/70R24
580/70R38

UNLADEN MACHINE SPEEDS (GOVERNED)

1406A:
1st gear 10,3 km/hr
2nd gear 19,0 km/hr
3rd gear 25,0 km/hr
4th gear 36,0 km/hr
5th gear 40,0 km/hr
6th gear 40,0 km/hr

1406AF:
1st gear 9,7 km/hr
2nd gear 18,0 km/hr
3rd gear 23,7 km/hr
4th gear 34,0 km/hr
5th gear 40,0 km/hr
6th gear 40,0 km/hr

SUSPENSION

Front
1406A: Coil springs on front axle.
1406AF: Centre pivot above the axle.

Rear
None

HYDRAULIC SYSTEM

Pump Application
Pump supplying steering (with priority flow valve) and hitch lift and trailer auxiliary (2 function direct lever control valve).

Rated Flow @ Engine Governed RPM
61,2 L/min

Control Valve Relief Pressure
210 bar

STEERING SYSTEM

Steering orbitrol valve

Lock-to-lock Turns
3,5

PNEUMATIC SYSTEM

System Pressure
8,4 bar

Air Reservoir Capacity
30 L

Auxiliary (Trailer) Air Supply
Quick coupler at vehicle rear

ELECTRICAL SYSTEM

Voltage
24 V

Alternator Rating
24V/80A

Battery Rating
100 Ah x 2

CAB

Fully enclosed with HVAC. ROPS certified to ISO5700:2013. FOPS certified to ISO27850:2013.

Mounting
Rubber

Operator Seat
Mechanical suspension. Lap strap restraining belt.

Ventilation
Heater Ventilation & Airconditioning (HVAC).

Operator Trainer Seat
Optional side mounted rigid seat with lap strap restraining belt.

Guarding
Full-size expanded mesh rear window cab guard.

Instrumentation
Air pressure, engine speed, machine speed, engine coolant temperature, fuel level and hour meter permanently displayed. Audible warning buzzer and colour change to red as warning of undesirable conditions.

OPERATING MASS

	1406A	1406AF
• Unladen Front	2 170 kg	3 081 kg
• Unladen Rear	3 764 kg	3 875 kg
• Unladen Total	5 933 kg	6 956 kg
• Rated Rear Axle Load	8 000 kg	8 000 kg
• Hitch Loading @ Rated Rear Axle Load	4 100 kg	4 100 kg
• Laden Front	2 252 kg	3 163 kg
• Laden Rear	7 781 kg	7 893 kg
• Laden Total Gross Vehicle Mass (GVM)	10 033 kg	11 056 kg
• Allowable Gross Combination Mass (GCM)	41 600 kg	41 600 kg

(Long range tank fitted as an option, no belly plates fitted)

FRONT BODYWORK

Bonnet
Front section one-piece fibre glass bonnet.

Hinges towards rear at an angle of 70 degrees for full-service access to coolers, engine and transmission.

Grill
Part of the bonnet.

Fluid Tanks
Side-side diesel / hydraulic tank.

Optional long-range spill over tank mounted to LHS of chassis.

Rear Mudguards
Steel with integrated tail-lights and front indicator lights

OPTIONS

- FM radio
- Fleetm@tic®
- Underside belly plates
- Long-range tank
- Trainer seat

DRIVE-BY NOISE EMISSION

SANS 10205:2007
88 dBA

HITCH

Certified Capacity:
5 097 kg

Hitch Forward of Rear Axle:
63 mm

FLUID CAPACITIES

• Hydraulic oil	120 L
• Diesel:	
- Standard	160 L
- Optional Long range	140 L
• Front axle oil	8,5 L
• Rear axle oil	32 L
• Engine oil	19 L
• Transmission oil	28 L
• Transfer case oil:	
- 1406A	N/A
- 1406AF	2,5 L

I Dimensions

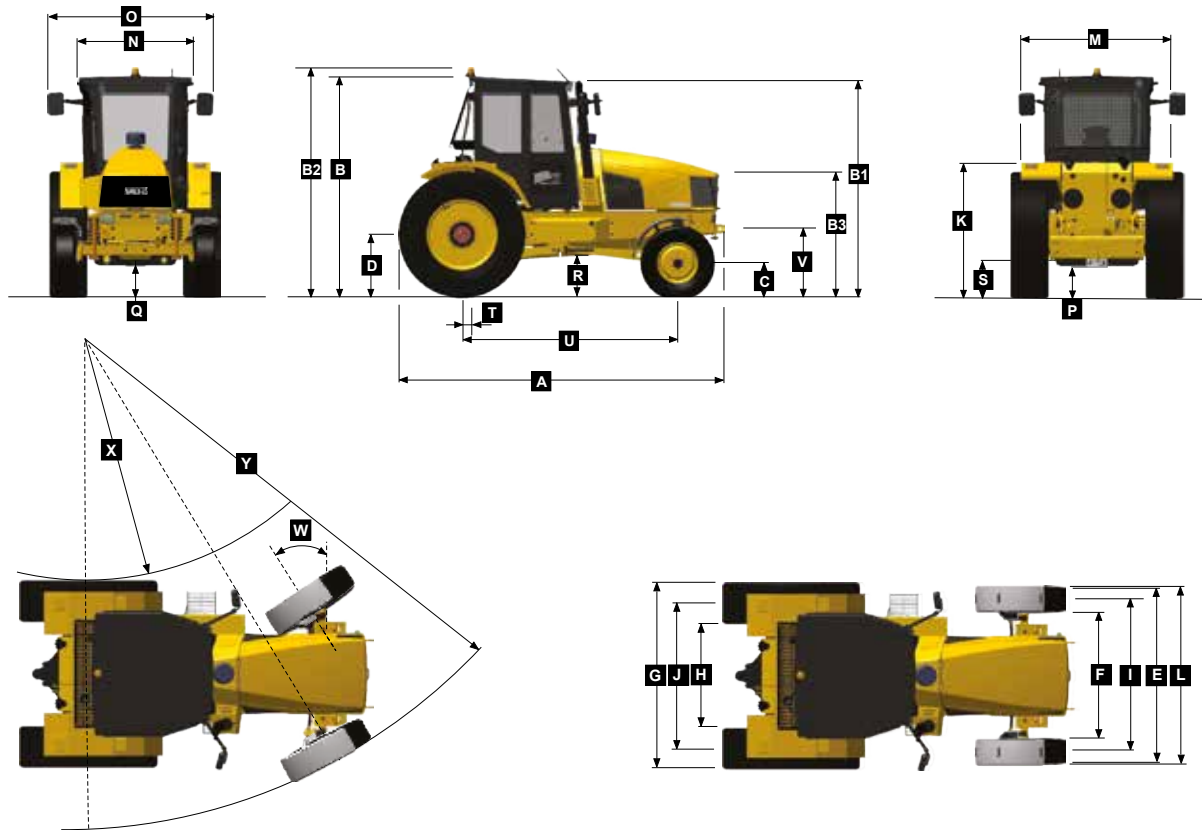

Machine Dimensions

A	Length-Transport Position	4 697 mm	L	Width over Mudguards Front	2 380 mm
B	Height-Cab	3 197 mm	M	Width over Mudguards Rear	2 172 mm
B1	Height-Exhaust Stack	3 146 mm	N	Width over Cab	1 675 mm
B2	Height-Rotating Beacon	3 317 mm	O	Width over Mirrors - Operating Position	2 393 mm
B3	Height-Bonnet Front	1 845 mm	P	Ground Clearance - Hitch	461 mm
C	Height-Front Axle Centre(Rolling Radius)	543 mm	Q	Ground Clearance - Front Axle	521 mm
D	Height-Rear Axle Centre (Rolling Radius)	915 mm	R	Ground Clearance - Max	648 mm
E	Width over Tyres-Front - 315/80 R22.5	2 292 mm	S	Height-Hitch Ball Centre	552 mm
F	Inside Tyre Width-Front	1 668 mm	T	Rear Axle Centre to Ball Hitch Centre	63 mm
G	Width over Tyres-Rear - 540/80 R38	2 476 mm	U	Front Axle Centre to Rear Axle Centre	3 106 mm
H	Inside Tyre Width - Rear	1 376 mm	V	Front Tie Down Height	1 036 mm
I	Tyre Track Width - Front	1 980 mm	W	Maximum Steering Angle	34°
J	Tyre Track Width - Rear	1 926 mm	X	Inner Turning Circle Radius	3 814 mm
K	Height-Rear Mudguard	1 963 mm	Y	Outer Turning Circle Radius	7 030 mm

All Dimensions are Unladen values based on the Standard Wheelset U.O.N

I Grade Ability/Rimpull

1. Determine the GCM (mass) of the Rig.
2. Estimate grade and find the corresponding (Red) line.
3. Where vertical (mass) line and Red (Grade) line cross.
4. Draw a horizontal line to intersect Tractive chart on the right.
5. Drop a vertical line at that point and read off max. speed at a given grade and mass.

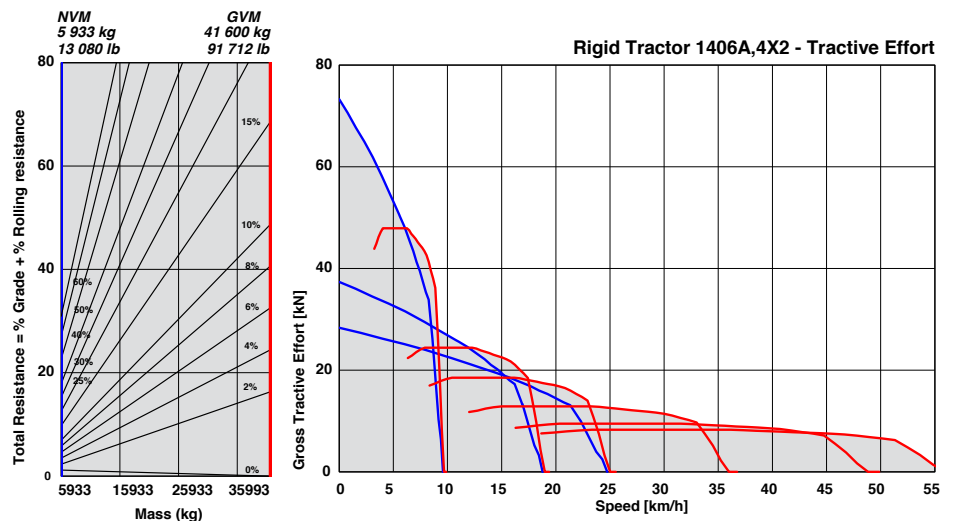

I406AF Series V

I Dimensions

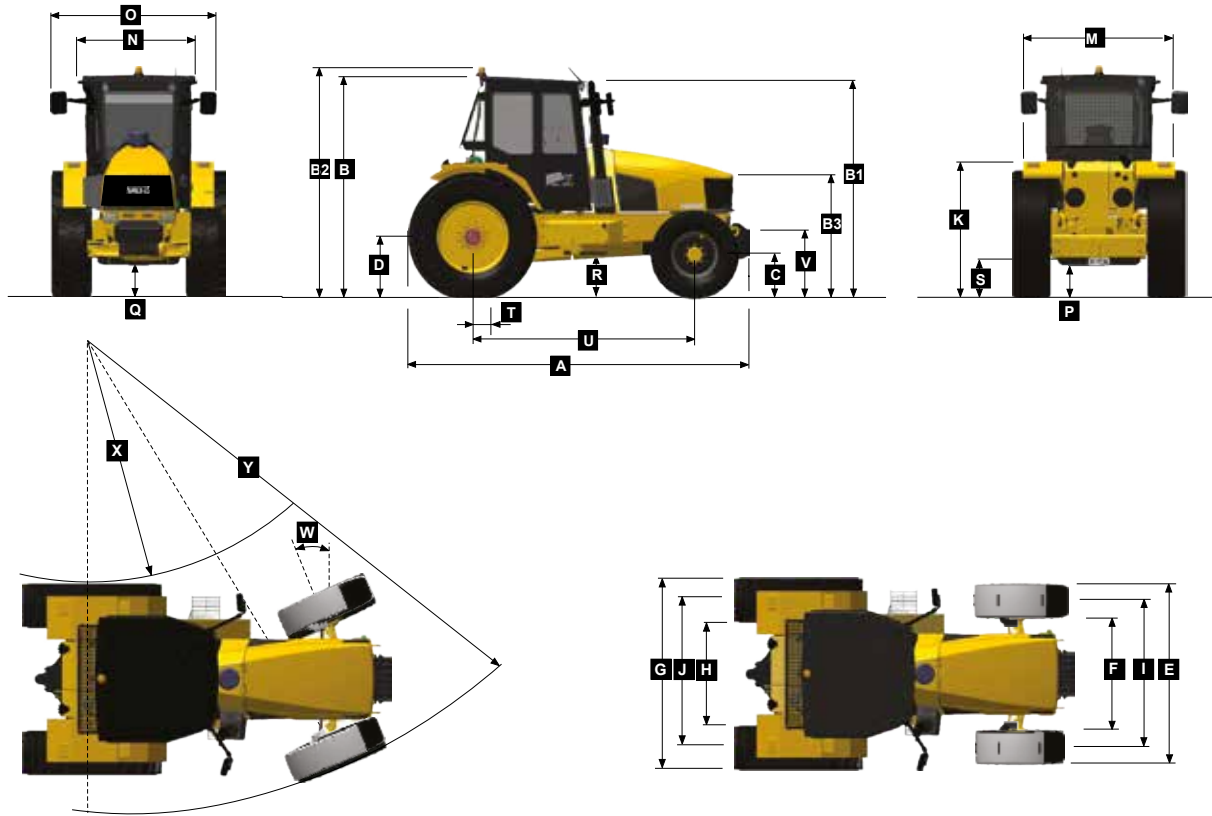

Machine Dimensions

A	Length-Transport Position	4 844 mm	M	Width over Mudguards Rear	2 172 mm
B	Height-Cab	3 195 mm	N	Width over Cab	1 675 mm
B1	Height-Exhaust Stack	3 104 mm	O	Width over Mirrors-Operating Position	2 393 mm
B2	Height-Rotating Beacon	3 313 mm	P	Ground Clearance-Hitch	458 mm
B3	Height-Bonnet Front	1 755 mm	Q	Ground Clearance-Front Axle	500 mm
C	Height-Front Axle Centre(Rolling Radius)	627 mm	R	Ground Clearance-Max	616 mm
D	Height-Rear Axle Centre (Rolling Radius)	918 mm	S	Height-Hitch Ball Centre	550 mm
E	Width over Tyres-Front-420/70 R24	2 288 mm	T	Rear Axle Centre to Ball Hitch Centre	54 mm
F	Inside Tyre Width-Front	1 450 mm	U	Front Axle Centre to Rear Axle Centre	3 142 mm
G	Width over Tyres-Rear-580/70 R38	2 510 mm	V	Front Tie Down Height	946 mm
H	Inside Tyre Width-Rear	1 342 mm	W	Maximum Steering Angle	25°
I	Tyre Track Width-Front	1 869 mm	X	Inner Turning Circle Radius	5 554 mm
J	Tyre Track Width-Rear	1 926 mm	Y	Outer Turning Circle Radius	8 617 mm
K	Height-Rear Mudguard	1 962 mm			

All Dimensions are Unladen values based on the Standard Wheelset U.O.N

I Grade Ability/Rimpull

1. Determine the GCM (mass) of the Rig.
2. Estimate grade and find the corresponding (Red) line.
3. Where vertical (mass) line and Red (Grade) line cross.
4. Draw a horizontal line to intersect Tractive chart on the right.
5. Drop a vertical line at that point and read off max. speed at a given grade and mass.

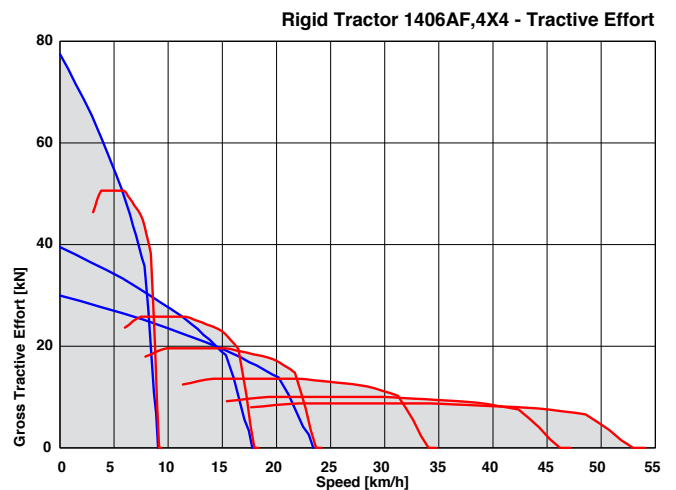
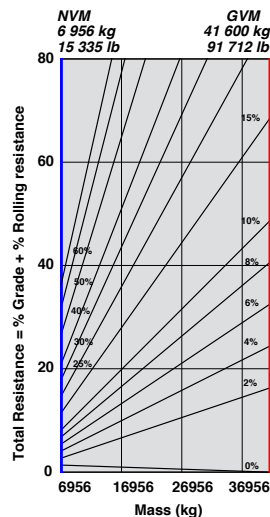

I 736A & I 736AF Series V Rigid Hauler Tractors



ENGINE

Model
John Deere 6068HF285

Configuration
Six-cylinder, in-line

Emission Certification
Tier III/Stage IIIA

Aspiration
Turbo charged & A/A intercooled

Displacement
6.8 Litre

Gross Power
173 hp / 129 kW

Torque Rise
32%

Governed Engine Speed
2 200 rpm

Maximum torque (Net, Nm @ RPM)
714 Nm @ 1 500 rpm

Compression ratio
19:1

Engine/Transmission Cooling
Custom built high debris tolerant cooling pack with spacing. Transmission cooler mounted side by side with the radiator and the CAC.

Engine Exhaust/Retardation
Rectangular canister silencer integrated in line in the exhaust system/Engine valve J - brake.

Engine Air Cleaner
Dual Stage air filter with heavy duty pre-cleaner.

TRANSMISSION

Model
Allison #3000

Torque Converter Layout
Hydrodynamic with lock-up in 1-6 gears and converter mode in gears 1 & 2

Allowable Maximum GCM
48 000 kg

TRANSFER CASE

Model
1736A: N/A
1736AF: Bell

Layout
1736A: N/A
1736AF: Mounted off the rear differential.

REAR AXLE

Bell structural steel 13 ton axle

Static Load Rating
32 500 kg

Dynamic Load Rating
13 000 kg

FRONT AXLE

1736A: Bell
1736AF: Carraro cast iron, steering axle, centre pivot, side input

Static Load Rating
1736A: 7 590 kg
1736AF: 5 750 kg

Dynamic Load Rating
1736A: 3 600 kg
1736AF: 3 600 kg

STEERING SYSTEM

Single steering cylinder with through-rod and adjustable tie-rod ends.

BRAKING SYSTEM AND BRAKING FORCE

Service Brake
Rear axle braking only

Park brake
Rear axle braking only

Specification Compliance
SANS 1447-1:2007 Ed.2

Pneumatic System Charge Pressure
8,5 bar

Park Brake Type
Spring applied and pneumatic released

WHEELS

1736A Wheels
600/65R38
315/80R22.5

1736AF Wheels
420/70R24
580/70R38

UNLADEN MACHINE SPEEDS (GOVERNED)

1736A:

1st gear	10,3 km/hr
2nd gear	19,3 km/hr
3rd gear	25,6 km/hr
4th gear	36,0 km/hr
5th gear	40,0 km/hr
6th gear	40,0 km/hr

1736AF:

1st gear	9,8 km/hr
2nd gear	18,3 km/hr
3rd gear	24,2 km/hr
4th gear	34,6 km/hr
5th gear	40,0 km/hr
6th gear	40,0 km/hr

SUSPENSION

Front
1736A: Coil springs on front axle.
1736AF: Centre pivot above the axle.

Rear
None

HYDRAULIC SYSTEM

Pump Application
Pump supplying steering (with priority flow valve) and hitch lift and trailer auxiliary (2 function direct lever control valve)

Rated Flow @ Engine Governed RPM
61,2 L/min

Control Valve Relief Pressure
210 bar

STEERING SYSTEM

Steering Orbitrol valve

Lock-to-lock Turns
3,5

PNEUMATIC SYSTEM

System Pressure
850 kPa

Air Reservoir Capacity
30 L

Auxiliary (Trailer) Air Supply
Quick coupler at vehicle rear

ELECTRICAL SYSTEM

Voltage
24 V

Alternator Rating
24V/80A

Battery Rating
100 Ah x 2

CAB

Fully enclosed with HVAC. ROPS certified to ISO5700:2013. FOPS certified to ISO27850:2013.

Mounting
Rubber

Operator Seat
Mechanical suspension. Lap strap restraining belt.

Operator Trainer Seat
Optional side mounted rigid seat with lap strap restraining belt.

Ventilation
Heater Ventilation & Airconditioning (HVAC)

Guarding
Full-size expanded mesh rear window cab guard.

Instrumentation
Air pressure, engine speed, machine speed, engine coolant temperature, fuel level and hour meter permanently displayed. Audible warning buzzer and colour change to red as warning of undesirable conditions.

OPERATING MASS

	1736A	1736AF
• Unladen Front	2 210 kg	3 121 kg
• Unladen Rear	3 844 kg	3 955 kg
• Unladen Total	6 053 kg	7 076 kg
• Rated Rear Axle Load	8 000 kg	8 000 kg
• Hitch Loading @ Rated Rear Axle Load	4 100 kg	4 100 kg
• Laden Front	2 292 kg	3 203 kg
• Laden Rear	7 861 kg	7 973 kg
• Laden Total Gross Vehicle Mass (GVM)	10 153 kg	11 176 kg
• Allowable Gross Combination Mass (GCM)	48 000 kg	48 000 kg

(Long range tank fitted as an option, no belly plates fitted)

FRONT BODYWORK

Bonnet
Front section one-piece fibre glass bonnet.

Hinges towards rear at an angle of 70 degrees for full-service access to coolers, engine and transmission.

Grill
Part of the bonnet

Fluid Tanks
Side-side diesel / hydraulic tank.

Optional long-range spill over tank mounted to LHS of chassis.

Rear Mudguards
Steel with integrated tail-lights, and front indicator lights

OPTIONS

- FM radio
- Fleetmatic®
- Underside belly plates
- Long-range tank
- Trainer seat

DRIVE-BY NOISE EMISSION

SANS 10205:2007
88 dBA

HITCH

Certified Capacity:
5 097 kg

Hitch Forward of Rear Axle:
65 mm

FLUID CAPACITIES

- Hydraulic oil 120 L
- Diesel:
 - Standard 160 L
 - Optional Long range 140 L
- Front axle oil 8,5 L
- Rear axle oil 32 L
- Engine oil 19 L
- Transmission oil 28 L
- Transfer case oil:
 - 1736A N/A
 - 1736AF 2,5 L

I736A Series V

I Dimensions

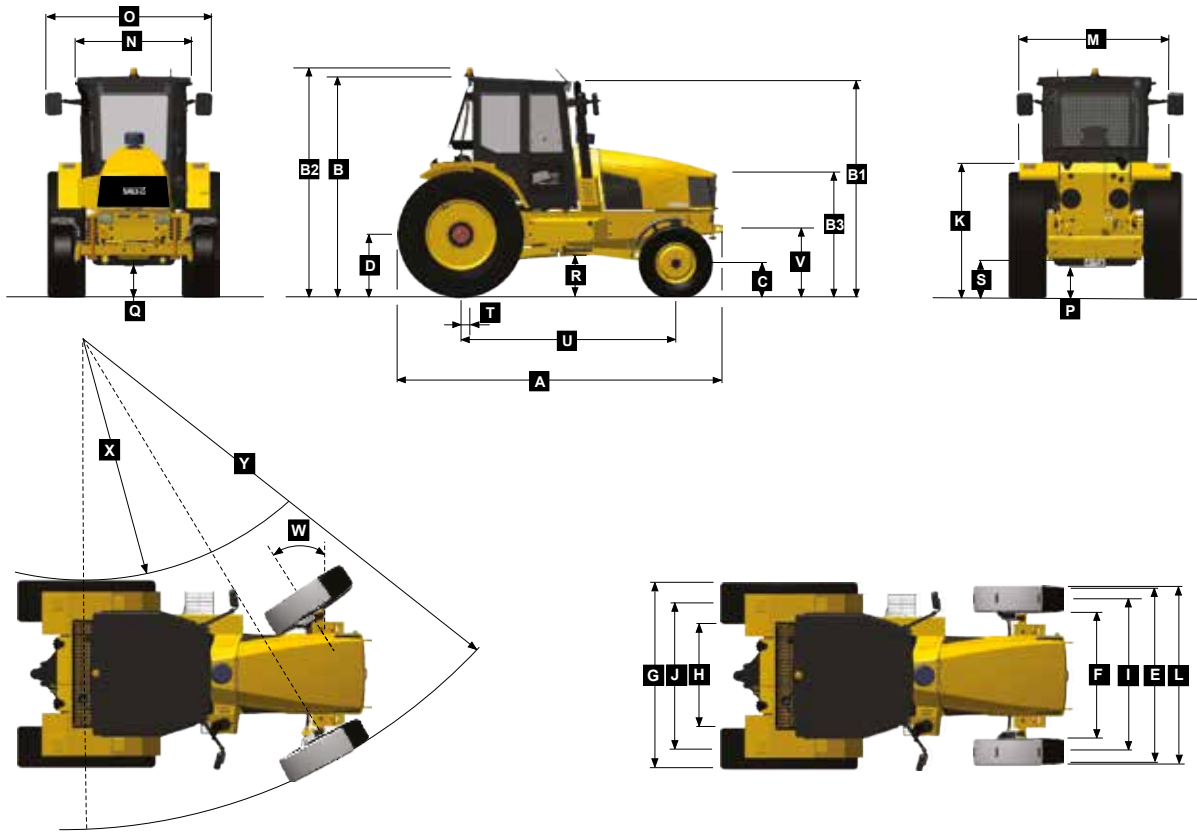

Machine Dimensions

A	Length-Transport Position	4 697 mm	L	Width over Mudguards Front	2 380 mm
B	Height-Cab	3 197 mm	M	Width over Mudguards Rear	2 172 mm
B1	Height-Exhaust Stack	3 146 mm	N	Width over Cab	1 675 mm
B2	Height-Rotating Beacon	3 317 mm	O	Width over Mirrors - Operating Position	2 393 mm
B3	Height-Bonnet Front	1 845 mm	P	Ground Clearance - Hitch	461 mm
C	Height-Front Axle Centre (Rolling Radius)	543 mm	Q	Ground Clearance - Front Axle	521 mm
D	Height-Rear Axle Centre (Rolling Radius)	915 mm	R	Ground Clearance - Max	648 mm
E	Width over Tyres-Front - 315/80 R22.5	2 292 mm	S	Height-Hitch Ball Centre	552 mm
F	Inside Tyre Width-Front	1 668 mm	T	Rear Axle Centre to Ball Hitch Centre	63 mm
G	Width over Tyres-Rear - 540/80 R38	2 476 mm	U	Front Axle Centre to Rear Axle Centre	3 106 mm
H	Inside Tyre Width - Rear	1 376 mm	V	Front Tie Down Height	1 036 mm
I	Tyre Track Width - Front	1 980 mm	W	Maximum Steering Angle	34°
J	Tyre Track Width - Rear	1 926 mm	X	Inner Turning Circle Radius	3 814 mm
K	Height-Rear Mudguard	1 963 mm	Y	Outer Turning Circle Radius	7 030 mm

All Dimensions are Unladen values based on the Standard Wheelset U.O.N

I Grade Ability/Rimpull

1. Determine the GCM (mass) of the Rig.
2. Estimate grade and find the corresponding (Red) line.
3. Where vertical (mass) line and Red (Grade) line cross.
4. Draw a horizontal line to intersect Tractive chart on the right.
5. Drop a vertical line at that point and read off max. speed at a given grade and mass.

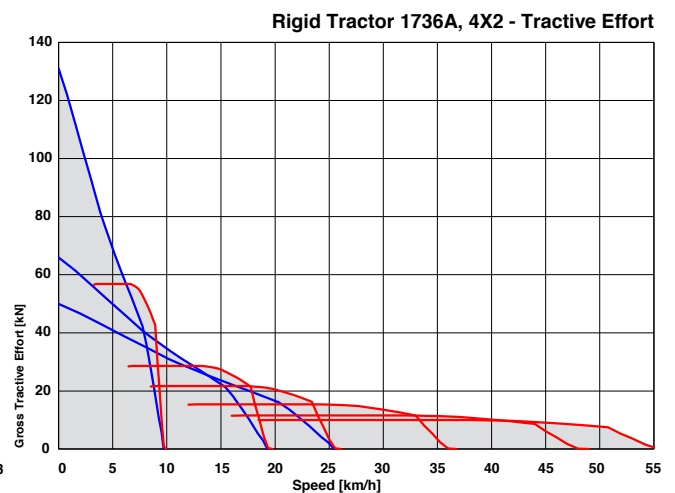
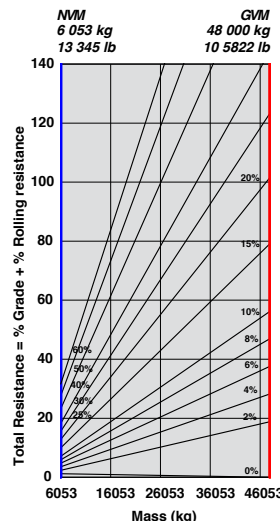

Dimensions

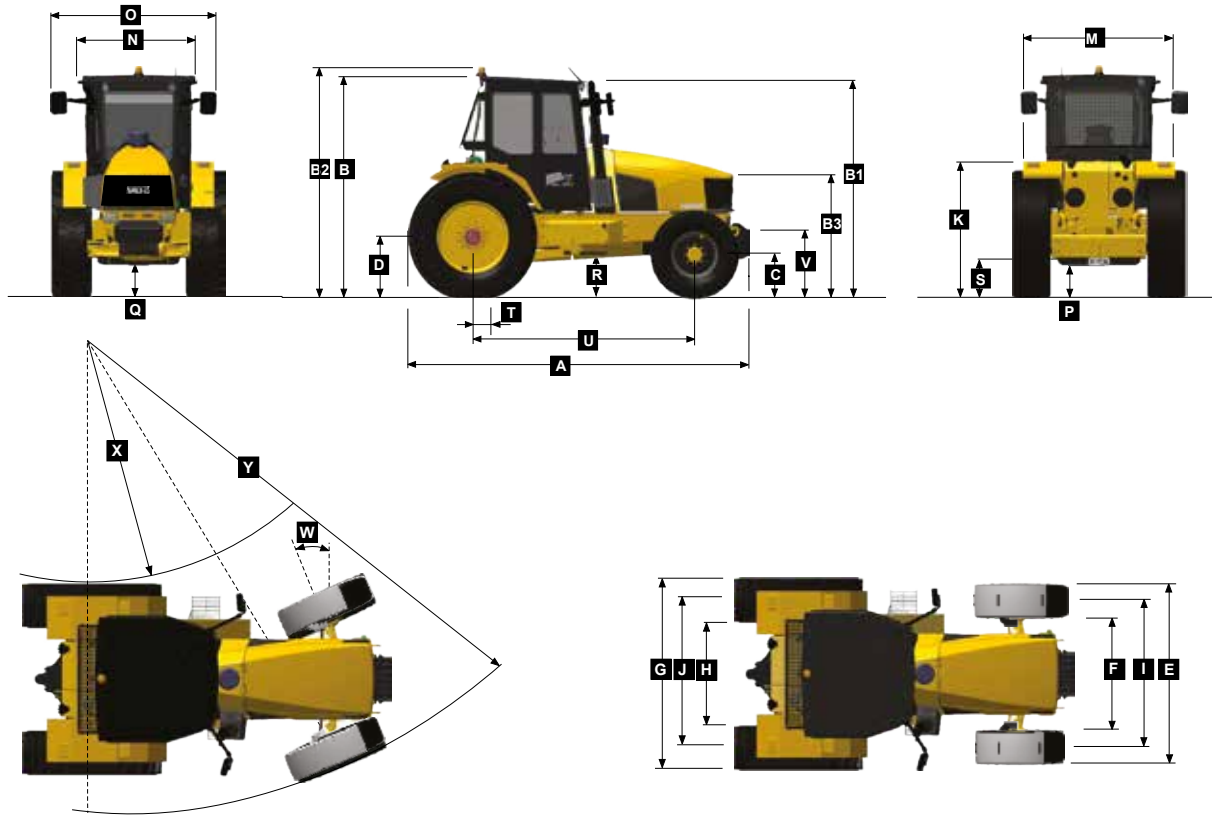

Machine Dimensions

A	Length-Transport Position	4 844 mm	M	Width over Mudguards Rear	2 172 mm
B	Height-Cab	3 195 mm	N	Width over Cab	1 675 mm
B1	Height-Exhaust Stack	3 104 mm	O	Width over Mirrors-Operating Position	2 393 mm
B2	Height-Rotating Beacon	3 313 mm	P	Ground Clearance-Hitch	458 mm
B3	Height-Bonnet Front	1 755 mm	Q	Ground Clearance-Front Axle	500 mm
C	Height-Front Axle Centre(Rolling Radius)	627 mm	R	Ground Clearance-Max	616 mm
D	Height-Rear Axle Centre (Rolling Radius)	918 mm	S	Height-Hitch Ball Centre	550 mm
E	Width over Tyres-Front-420/70 R24	2 288 mm	T	Rear Axle Centre to Ball Hitch Centre	54 mm
F	Inside Tyre Width-Front	1 450 mm	U	Front Axle Centre to Rear Axle Centre	3 142 mm
G	Width over Tyres-Rear-580/70 R38	2 510 mm	V	Front Tie Down Height	946 mm
H	Inside Tyre Width-Rear	1 342 mm	W	Maximum Steering Angle	25°
I	Tyre Track Width-Front	1 869 mm	X	Inner Turning Circle Radius	5 554 mm
J	Tyre Track Width-Rear	1 926 mm	Y	Outer Turning Circle Radius	8 617 mm
K	Height-Rear Mudguard	1 962 mm			

All Dimensions are Unladen values based on the Standard Wheelset U.O.N

Grade Ability/Rimpull

1. Determine the GCM (mass) of the Rig.
2. Estimate grade and find the corresponding (Red) line.
3. Where vertical (mass) line and Red (Grade) line cross.
4. Draw a horizontal line to intersect Tractive chart on the right.
5. Drop a vertical line at that point and read off max. speed at a given grade and mass.

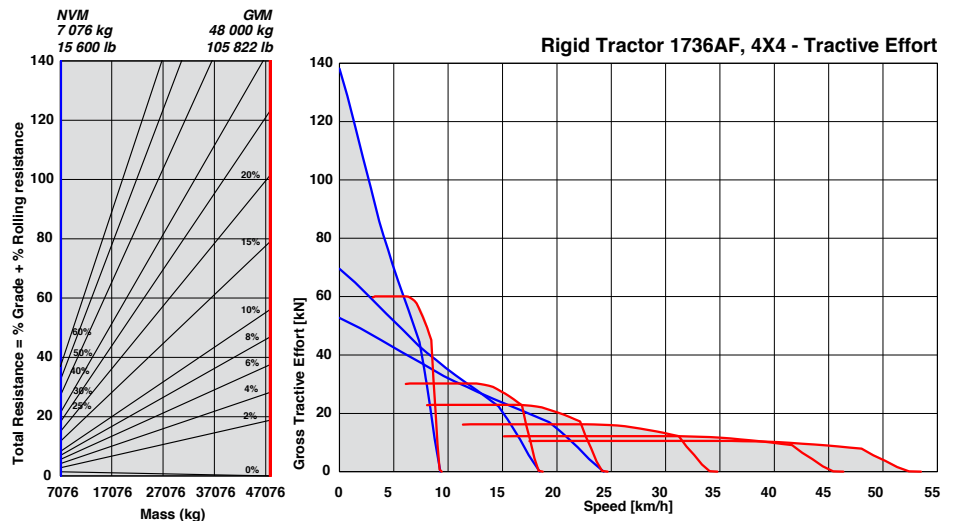



All dimensions are shown in millimetres, unless otherwise stated between brackets. Under our policy of continuous improvement, we reserve the right to change technical data and design without prior notice. Photographs featured in this brochure may include optional equipment.

BELL INTERNATIONAL: Tel: +27 (0)35-907 9431

E-mail: marketing@bellequipment.com

Web: www.bellequipment.com



Tel: +61 (0)8-9355-2442



Tel: +33 (0)5-55-89-23-56



Tel: +49 (0)6631 / 91-13-0



Tel: +7-495-287-80-02



Tel: +27 (0)11-928-9700



Tel: (704) 655 2802



Tel: +44 (0)1283-712862

• G809511 • G810511 • G811511 • G812511

**Strong Reliable Machines
Strong Reliable Support**

BELL